



**#FIT**

**Breaker Failure Protection IED**

**Instruction Manual**

**ZIV APLICACIONES Y TECNOLOGÍA, S.A.**  
**End-User Software License Agreement**

**THIS IS A LEGAL AGREEMENT BETWEEN YOU (AS "LICENSEE") AND ZIV APLICACIONES Y TECNOLOGIA, S.A. (AS "LICENSOR") FOR THE SOFTWARE PROGRAM YOU HAVE PURCHASED. PLEASE READ THE TERMS AND CONDITIONS OF THIS LICENSE AGREEMENT CAREFULLY BEFORE USING THE PROGRAM DISKETTES. THE PROGRAM IS COPYRIGHTED AND LICENSED TO YOU (NOT SOLD).**

**IF YOU INSTALL, USE OR COPY THE SOFTWARE PROGRAM, YOU ARE ACCEPTING AND AGREEING TO THE TERMS OF THIS LICENSE AGREEMENT. IF YOU ARE NOT WILLING TO BE BOUND BY THE TERMS OF THIS LICENSE AGREEMENT, YOU SHOULD PROMPTLY RETURN THE ENTIRE CONTENTS OF THIS PACKAGE TO YOUR SELLER.**

**Terms and Conditions of License**

**1. License Grant.** Licensor hereby grants to you, and you accept, a nonexclusive license to use the Program Diskettes and the computer programs contained therein in machine-readable, object code form only, and the accompanying documentation (collectively referred to as the "Software"), only as authorized in this License Agreement. You may use the program(s) solely in your internal operations at all facility sites you own but only with the type of machines and equipment specified in the printed material furnished by Licensor and only in accordance with the instructions given in such material.

**2. Restrictions.** You may not: (a) use, copy, modify or transfer the Software except as expressly provided in this or another Agreement with Licensor, (b) reverse engineer, decompile or disassemble or separate the components of the Software, or (c) rent, sell or lease the Software or make the Software available to others to do any of the foregoing.

**3. Back-Up.** Upon loading the Software into your computer, you may retain the Program Diskette for backup purposes. In the event the program diskettes are damaged, you may return them to Licensor, at your expense, and obtain a new copy free of charge.

**4. No Assignment.** The License is intended for your exclusive use. You agree that you will not assign, sublicense, transfer, pledge, lease, rent or share your rights under this License Agreement.

**5. Licensor's Rights.** You acknowledge and agree that the Software is the proprietary product of Licensor protected under International laws and treaties. You further acknowledge and agree that all right, title and interest in and to the Software, including associated intellectual property rights, are and shall remain with Licensor. This License Agreement does not convey to you an interest in or to the Software, but only a limited right of use revocable in accordance with the terms of this License Agreement.

**6. Confidentiality.** The Software is confidential and no details or information relating to the same shall be disclosed to any third party without the prior written consent of Licensor.

**7. Term.** This License Agreement is effective upon your opening of the package and shall continue until terminated. You may terminate this License Agreement at any time by returning the Software and all copies thereof and extracts therefrom to Licensor, or by destroying all tangible copies of the Software. Licensor may terminate this License Agreement upon your breach of any term hereof. Upon such termination by Licensor, you agree to return to Licensor the Software and all copies and portions thereof, or destroy all tangible copies of the Software, and to erase all copies of the Software held in computer memory or otherwise.

**8. AS IS.** THE SOFTWARE IS LICENSED "AS IS" AND WITHOUT A WARRANTY OF ANY KIND. LICENSOR EXPRESSLY DISCLAIMS ANY AND ALL OTHER WARRANTIES, WHETHER EXPRESS OR IMPLIED, INCLUDING, WITHOUT LIMITATION, ANY IMPLIED WARRANTIES OF MERCHANTABILITY OR FITNESS FOR A PARTICULAR PURPOSE. LICENSOR DOES NOT WARRANT THAT THE FUNCTIONS CONTAINED IN THE SOFTWARE WILL MEET UNINTERRUPTED OR ERROR FREE. THE ENTIRE RISK AS TO THE QUALITY AND PERFORMANCE OF THE SOFTWARE IS WITH YOU.

**9. Limitation of Liability.** Licensor's sole and entire liability, and your exclusive remedy, with respect to any claims relating to the Software shall be to provide a new set of diskettes free of charge. **In no event shall Licensor be liable for any indirect, incidental, consequential, special, or exemplary damages or lost profits, even if Licensor has been advised of the possibility of such damages,**

**10. Licensee's Indemnity.** You shall defend, indemnify and hold Licensor harmless against any loss or damage of any kind arising from a breach by you of this License Agreement, or any use or misuse of the Software by you or your employees, agents, or representatives, and from any other of your conduct or from any claim or action by any of your customers in connection with the Software or this License Agreement.

**11 Governing Law.** This License Agreement shall be construed and governed in accordance with the internal laws of the State of Illinois, U.S.A..

**12. No Waiver.** The failure of either party to enforce any rights hereunder or to take action against the other party in the event of any breach hereunder shall not be deemed a waiver by that party as to subsequent enforcement of rights or subsequent actions in the event of future breaches.

**13. Entire Agreement.** This License Agreement is the entire agreement between you and Licensor with respect to the use of the Software and supersedes all prior understandings or agreements between the parties. This License Agreement may be amended only by a writing by an officer of Licensor.

**ZIV Aplicaciones y Tecnología, S.A.  
Apartado de Correos 757  
48080 BILBAO**

**SPAIN**

**Telephone: +34 (94) 452 2003**

**WARNING**

ZIV Aplicaciones y Tecnología, S.A. has all rights reserved on this manual. No part of this manual shall be reproduced, stored in a retrieval system, or transmitted by any means, electronic, mechanical, photocopying, recording, or otherwise, without written permission from the Licensor.

All terms mentioned in this manual are only for information purposes.

ZIV Aplicaciones y Tecnología, S.A. does not assume any liability for damages resulting from the unilateral use of the information contained in this manual.

# Index

<b>CHAPTER 1. Description</b> .....	<b>1-1</b>
1.1 Functions .....	1-2
1.2 Additional Functions .....	1-3
1.3 Model Selection .....	1-4
<b>CHAPTER 2. Technical Characteristics</b> .....	<b>2-1</b>
<b>CHAPTER 3. Standards and Type Tests</b> .....	<b>3-1</b>
<b>CHAPTER 4. Physical Architecture</b> .....	<b>4-1</b>
4.1 General .....	4-2
4.2 Dimensions .....	4-3
4.3 Connection Elements .....	4-4
4.3.1 Terminal Connectors and Connector Blocks .....	4-4
4.3.2 Plug Type Connectors (Non Self-shorting) .....	4-6
4.3.3 Removing of Printed Circuit Boards (Non Self-shorting) .....	4-6
4.3.4 Wiring .....	4-6
<b>CHAPTER 5. Settings</b> .....	<b>5-1</b>
<b>CHAPTER 6. Description of Operation</b> .....	<b>6-1</b>
6.1 Breaker Failure Unit .....	6-2
6.1.1 Single-Phase Trip .....	6-4
6.1.2 Three-Phase Trip with Overcurrent .....	6-4
6.1.3 Three-Phase Trip without Overcurrent .....	6-4
6.2 Contact Inputs, Outputs and LED Targets .....	6-5
6.2.1 Status Contact Inputs .....	6-5
6.2.2 Auxiliary Contact Outputs .....	6-6
6.2.3 LED Targets .....	6-7
6.3 Setting Group Change .....	6-8
6.3.1 Operation .....	6-9
6.4 Event Record .....	6-9
6.5 Current History Record .....	6-11
6.6 Oscillography Register (Optional) .....	6-12
6.7 Communications .....	6-14
6.7.1 Communications Settings .....	6-14
6.7.2 Communications Types .....	6-14
6.7.3 Communication with the Unit .....	6-14
6.8 Alarm Codes .....	6-15

<b>CHAPTER 7. Alphanumeric Keypad and Display</b> .....	<b>7-1</b>
7.1 Alphanumeric Display and Keypad .....	7-2
7.2 Keys, Functions and Operation Modes .....	7-3
7.3 Access to Functions Using Key F2 .....	7-5
7.3.1 Last Trip Indication .....	7-5
7.3.2 Screen Sequences Using F2 .....	7-6
7.4 Function Access Using the Keypad .....	7-6
<b>CHAPTER 8. Receiving Test</b> .....	<b>8-1</b>
8.1 General .....	8-2
8.1.1 Accuracy .....	8-2
8.2 Preliminary Inspection .....	8-3
8.3 Isolation Test .....	8-3
8.4 Power Supply Test .....	8-4
8.5 Current Metering Test .....	8-4
8.6 Breaker Failure Test .....	8-4
8.6.1 Times .....	8-5
8.7 Status Contact Inputs and LEDs Supervisión Test .....	8-5
8.8 Communication Test .....	8-6
8.9 Installation .....	8-6
<b>CHAPTER 9. Figures</b> .....	<b>9-1</b>
<b>Schemes and Drawings</b>	
<b>ANNEX A. Protection Communications Protocol PROCOME 3.0</b> .....	<b>A-1</b>
A.1 Settings .....	A-2
A.2 Description of Operation .....	A-3
A.2.1 General Settings .....	A-3
A.2.2 Pickup Report .....	A-3
A.2.3 Event Record .....	A-3
A.2.4 Fault Report .....	A-4
A.2.5 Inputs .....	A-4
A.2.6 Communicating with the Unit .....	A-4
A.3 Alphanumeric Keyboard and Display .....	A-5
A.3.1 Communications .....	A-5
A.3.2 Settings .....	A-5
A.3.2.a Logic Settings .....	A-5
A.3.2.b Historical .....	A-5
A.3.3 Accessing the Information .....	A-5
<b>ANNEX B. DNP 3.0 Protocol</b> .....	<b>B-1</b>
B.1 Physical Architecture .....	B-2
B.2 Settings .....	B-2
B.3 Description of Operation .....	B-3
B.3.1 DNP 3.0 Protocol .....	B-3
B.3.2 Communications .....	B-7
B.3.2.a Communication with the Equipment .....	B-7
B.4 Keypad and Alphanumeric Display .....	B-7
B.4.1 DNP3.0 Protocol .....	B-7
B.4.2 Information Access .....	B-8

## Index

<b>ANNEX C. MODBUS RTU Protocol</b> .....	<b>C-1</b>
C.1 Preliminary Information .....	C-2
C.2 Reading if Outputs (Read Coil Status) .....	C-3
C.3 Reading if Inputs (Read Input Status) .....	C-4
C.4 Reading of Metering Register (Read Input Registers) .....	C-5
C.5 Commands (Force Single Coil) .....	C-6

Notes:

## CHAPTER 1

# Description

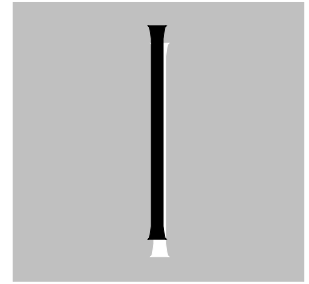

**#FIT** represents a family of terminal units for line/machine positions. The **#FIT** digital design is based on a powerful microprocessor with a breaker failure protection unit.

**#FIT** terminal are applicable in those positions with single or three-polar trip, where a breaker supervision is required.

# 1.1 Functions

- **Breaker failure Protection with single-phase or three-phase initiate (50s+62)**

Breaker failure (BF) protection includes two independent units per phase; each unit is comprised of a fast reset current level detector.

Also, it includes two digital inputs for initialization of the BF protection under 3-phase tripping with or without overcurrent conditions. For no-overcurrent conditions, the protection scheme takes into account the status of the circuit breaker and follows a particular logic.

When any of the units per phase is activated the BF protection timer will run. The output of this timer will activate the BF protection contacts.

The relay will memorize the BF protection indication to be reset through digital input.

BF protection can be set as “enabled” or “disabled”.

BF protection will activate two heavy duty double contacts; one of them for pick-up indication and the other one for BF indication.

Auxiliary outputs available in the relay can be easily configured for BF indication or others. In the same way, the relay includes optical indication by 4 configurable LEDs.

## 1.2 Additional Functions

- **LED Targets**

Terminal unit front panel indication consists of five LEDs. Four of the LEDs are user definable. The fifth LED is always assigned to indicate the terminal unit is **Ready** (powered up, self-test OK).

- **Status Contact Inputs**

The #FIT system has 7 status contact inputs all of them configurable.

- **Analog Inputs**

The #FIT system has 8 analog inputs (7 of them configurables).

- **Trip Outputs**

2 power outputs are provided, one of them for the breaker failure unit pick up and another one for the output activation.

- **Local Information (Display and Keypad)**

Display of:

**Operations:**

Last trip.  
Activated LEDs.

**Records:**

Event Recording.  
Current History Record.

**Meterings:**

Phase Currents.  
Maximum Current.

- **Self-Test Program**

A continuously running diagnostic self-test program verifies the correct operation of the terminal unit and alerts the user to potential problems.

### In option

Test element.

Oscillographic Register and Integrated Simulator.



CHAPTER 2

# Technical Characteristics

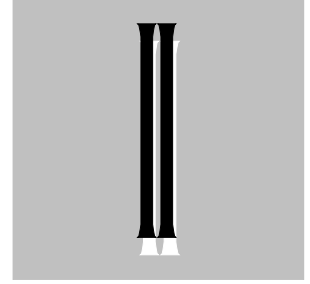

## Chapter 2

### Power Supply Voltage

**24 - 48 Vcc ( $\pm 20\%$ )**  
**110 - 125 Vcc ( $\pm 20\%$ )**  
**220 - 250 Vcc ( $\pm 20\%$ )**

Note: in case of an auxiliary power supply voltage failure, terminal units can tolerate a maximum interruption of 100ms at 110Vdc.

### Power Supply Loads

Quiescent **7 W**  
Maximum **20 W**

### Current Inputs

Rated ac Current ( $I_n$ )  **$I_n = 5A$**   
Thermal Withstand Capability  **$4 I_n$  (continuously)**  
 **$50 I_n$  (for 3s)**  
 **$100 I_n$  (for 1s)**  
Dynamic Limit  **$240 I_n$**   
Current Circuit Burden  **$I_n = 5A < 0.2VA$**

### Accuracy of Time Measurement

Definite Time and Inverse Time:  
(UNE 21-136 and CEI 255)  **$E = 5\%$  or **25 ms****  
(whichever is greater)

**Status Contact Inputs**

Separated programmable inputs, with polarity.

Rated Voltage:

IN1 Input

**110 Vca ± 20 %**

**125 Vdc ±20%**

IN2 to IN8 Input

**24 - 125 Vdc ±20 %**

(according to model)

**48 - 250 Vdc ±20 %**

Current Drain:

**< 5 mA**

**Trip and Close Outputs**

2 contacts normally open, one of which is configurable internally to closed

Maximum Current Limit:

**30 A in 1 s.**

(with resistive load)

Continuous Service Current:

**8 A**

(with resistive load)

Connection Capacity:

**2500 W**

Break Capacity: (with resistive load)

**180 W**

**1250 VA**

Break Capacity (L/R = 0,04 s):

**60 W to 125 Vdc**

Connection Voltage:

**250 Vdc**

Momentary Contact Close Time:

**100 ms (minimum)**

**Auxiliary Contact Outputs**

Electrically separate open and closed contacts and normally open contacts

Maximum Current Limit:

**5 A in 30 s.**

(with resistive load)

Continuous Service Current:

**3 A**

(with resistive load)

Connection Capacity:

**2000 W**

Break Capacity (with resistive load):

**75W -max. 3A- (up to 48 Vdc)**

**40W (80Vdc - 250Vdc)**

**1000 VA**

Break Capacity (L/R = 0,04 s):

**20 W to 125 Vdc**

Connection Voltage:

**250 Vdc**

## Chapter 2

### Repeatability

Operating Time: 2 % or 25 ms (whichever is greater)

### Communication Links

#### Glass Fiber Optics:

Type:	<b>Multimode</b>
Wavelength:	<b>820 nm</b>
Connector:	<b>ST</b>
Transmission Minimum Power:	
Fiber of 50/125:	<b>- 20 dBm</b>
Fiber of 62.5/125:	<b>- 17 dBm</b>
Fiber of 100/140:	<b>- 7dBm</b>
Receiver Sensitivity:	<b>- 25.4 dBm</b>

#### Plastic Fiber Optics (1 mm):

Wavelength:	<b>660 nm</b>
Transmission Minimum Power:	<b>- 16 dBm</b>
Receiver Sensitivity:	<b>- 39 dBm</b>

#### RS232C Port Signals

Front Connector DB-9 (9 pin)::	<b>Pin 2 – RXD</b>
	<b>Pin 3 – TXD</b>
	<b>Pin 5 - GND</b>
Remote Connector DB-25 (25 pin):	
	<b>Pin 2 - TXD</b>
	<b>Pin 3 - RXD</b>
	<b>Pin 4 - RTS</b>
	<b>Pin 5 - CTS</b>
	<b>Pin 7 - GND</b>
	<b>Pin 13 - +5V</b>
	<b>Power supply for adaptators modules</b>

CHAPTER 3

# Standards and Type Tests

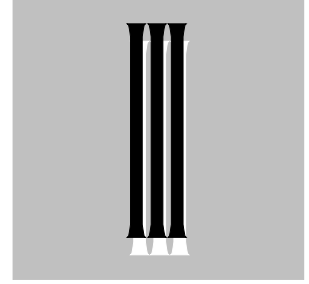

## Chapter 3

The IED's satisfies the requirements specified in the following boxes. In the case that there are no specifications, use the requirements of **UNE 21-136 (CEI-255)**.

<b>Insulation Test</b>	IEC-255-5	
Between circuitry and ground:		<b>2 kV, 50 Hz</b> , for 1min
Between all circuitry:		<b>2 kV, 50 Hz</b> , for 1min
<b>Voltage Impulse Test</b>	IEC-255-5 (EN 21-136-83/ 5)	<b>5 kV; 1,2/50 <math>\mu</math>s; 0,5 J</b>

<b>1 MHz Burst Disturbance Test</b>	IEC-255-22-1 Class III (EN 21-136-92/22-1)	
Common Mode:		<b>2,5 kV</b>
Differential Mode:		<b>1,0 kV</b>
<b>Fast Transient Disturbance Test</b>	IEC-255-22-4 Class IV (EN 21-136-92/22-4) (IEC 1000-4-4)	
<b>Radiated Electromagnetic Field Disturbance</b>	IEC 1000-4-3	
Amplitude Modulation	(ENV 50140)	<b>10 V/m</b>
Pulse Modulation	(EN 50204)	<b>10 V/m</b>
<b>Conducted Electromagnetic Field Disturbance</b>	EN 50141	
Amplitude Modulation		<b>10 V</b>
<b>Electrostatic Discharge Test</b>	IEC 255-22-2 Class III(EN 21-136-92/22-2)(IEC 1000-4-2)	<b>8 Kv <math>\pm</math> 10 %</b>

<b>Radio Frequency Emissivity</b>	ENV 55011 (IEC 1000-4-6)
-----------------------------------	--------------------------

<b>Temperature</b>	CEI 255-6	
Operating Range:		From <b>- 10 °C</b> to <b>+ 55 °C</b>
Storage Range:		From <b>- 25 °C</b> to <b>+ 70 °C</b>
Humidity:		<b>95 %</b> ( non condensing)



## Chapter 3

Notes:

CHAPTER 4

# Physical Architecture

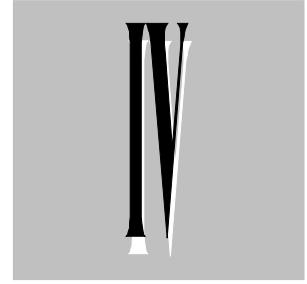

## 4.1 General

### • 8FIT Models

The **8FIT** protection terminals consist of two printed circuit boards. The main board provides the functions:

- **Power supply**
- **Central processor module (CPU)**
- **Analog inputs**
- **Contact inputs and outputs**

The second board includes analog inputs and can additionally be used as expansion for inputs/outputs.

### • 3FIT Models

Three boards form the **3FIT** terminals:

- **A printed circuit board with the analog inputs of the transformer secondary**
- **A printed circuit board that contains the CPU**
- **A printed circuit board that contains the power supply and contact inputs and outputs**

Depending on the IED settings, contact inputs / outputs may be used or remain as spares.

The external view of the ¼ rack **3FIT** terminal is represented in figure 4.1 and the **8FIT** is represented in figure 4.2. In the **8FIT** family, a hardware variation exists where the keypad and alphanumeric display are omitted (figure 4.3).

On the front are the keypad and alphanumeric display (in cases where they are included), the local communications port, and the LED's. In the case of the **3FIT**, the front of the expansion bus is shown.

In the back of the terminal are the connectors of each of the printed circuit boards and the remote communications port. The arrangement varies between models.

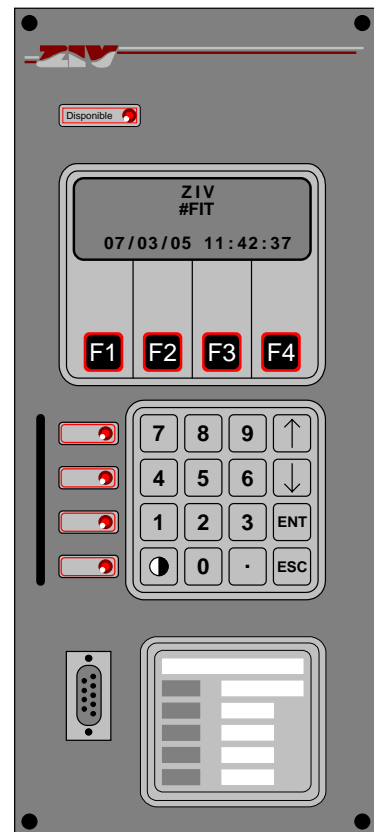

Figure 4.1: ¼ Rack 3FIT Front View.



Figure 4.2: 8FIT Front View (2U x 19" Rack).

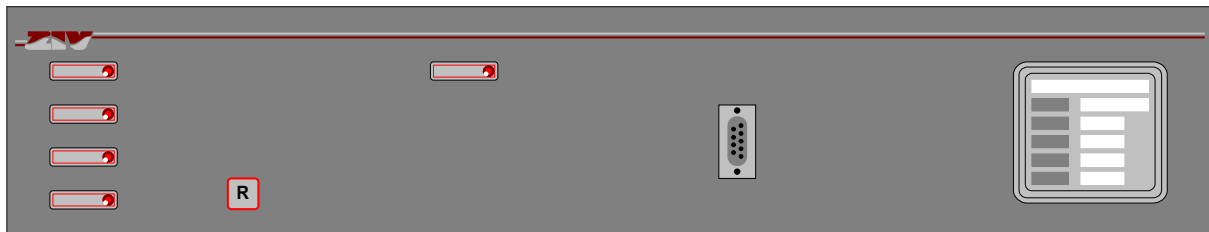

Figure 4.3: 8FIT (without a Keypad) Front View (19" Rack).

## 4.2 Dimensions

The different models are assembled in the following form:

- **3FIT** Models in 1/4 rack enclosure of 19", and 6 rack units high.
- **8FIT** Models in 1 rack enclosure of 19", and 2 or 4 rack units high.

The terminal is ready for installation in panel or in rack cabinet. The enclosure color is graphite. The **3FIT** terminals come with a transparent and sealable cover.

## 4.3 Connection Elements

### 4.3.1 Terminal Connectors and Connector Blocks

The number of terminal connectors depends on the number of digital inputs/outputs. The terminal connector blocks have different forms depending on the model.

- **3FIT Models**

The terminal connector blocks are vertically aligned as shown in figure 4.4 and arranged in columns as follows:

- 1 column of inputs for current transformers distributed in two connector blocks with 10 connectors each.
- 1 column of contact inputs/outputs distributed in two connector blocks of 32 contacts each (64 connectors)

The arrangement of the terminal connector blocks is shown in figure 4.4.

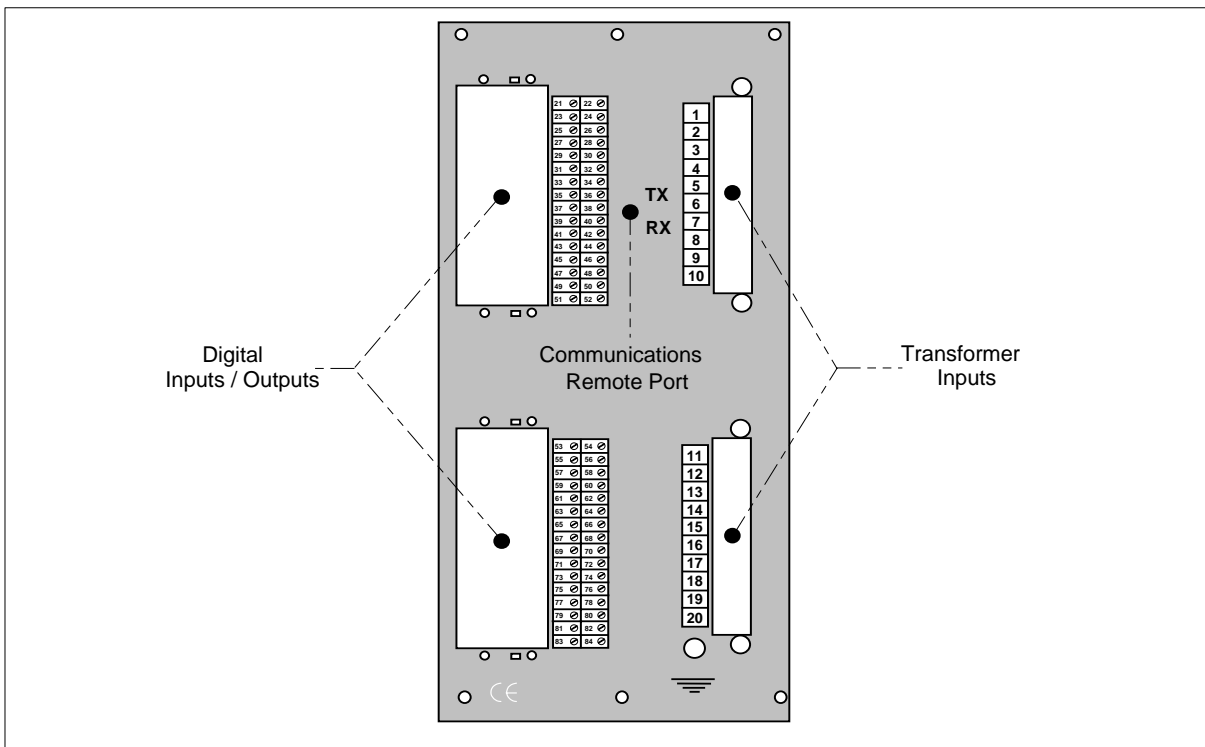

Figure 4.4: Rear View of a 3FIT of 1/4 Rack.

- **8FIT Model (2 Rack Units High)**

The terminal blocks are horizontally aligned as shown in figure 4.5 and arranged in rows as follows:

- 1 row with 2 terminal blocks having 24 connectors each (48 connectors) for the digital inputs and outputs and 1 terminal block with 10 connectors for the analog inputs connected to the current transformers.
- 1 row with 1 terminal block having 10 connectors for the analog inputs from the current transformers, and optionally there can be 2 terminal blocks with 24 connectors each (48 total) for the optional digital inputs and outputs expansion.

Analog input connectors accept up to #11 AWG wire. The remaining connectors allow wire up to #14 AWG. It is recommended the use of pin terminals.

Communications connectors are provided on both front and rear panels.

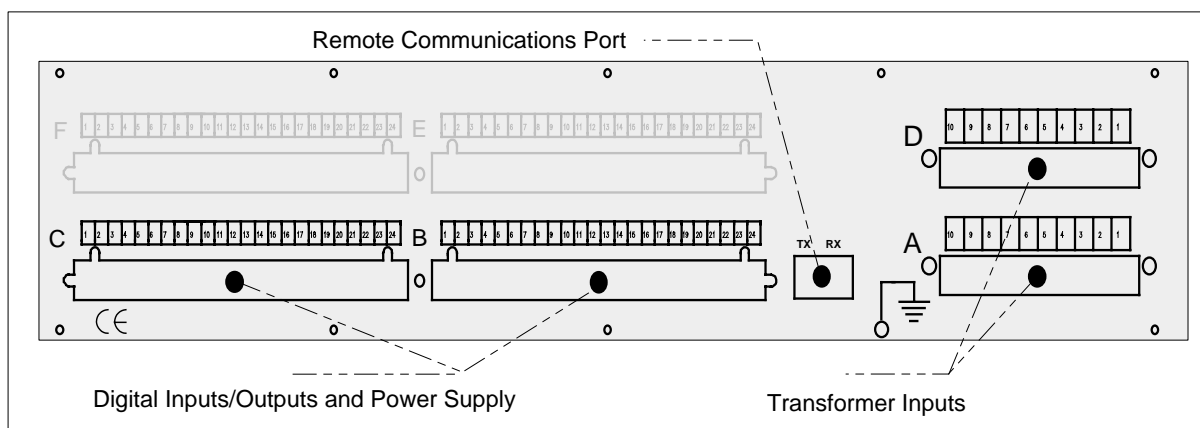

**Figure 4.5: Rear View of an 8FIT (2 Rack Units High).**

### 4.3.2 Plug Type Connectors (Non Self-shorting)

The current circuits can support a constant current of  $I_n = 20A$ .

### 4.3.3 Removing of Printed Circuit Boards (Non Self-shorting)

While it is possible to extract some of the electronic pc boards, **the current circuit terminal connectors are not self-shorting. Consequently, current transformer secondaries must be short-circuited before proceeding with board removal.**

The electronic pc boards have screws that should be removed before proceeding with the board removal. Before performing this operation, the protection terminal should be **"out of service"**.

### 4.3.4 Wiring

The system has internal connectors and buses to minimize internal wiring.

CHAPTER 5

# Settings



## Chapter 5

### • Configuration Settings

#### Passwords

The default **Password** which enables access to every terminal unit setting is **2140**. This password can be modified by the user to control access for any or all of the following functions: **Configuration, Operations and Settings**.

Remote Setting from:

Remote Port

**YES/NO**

Digital Inputs

**YES/NO**

#### Inputs, Status Contact Outputs and LED Targets Configuration

The unit is supplied with the factory default configuration for inputs, outputs and LED's. Inputs, outputs, and LED's can be redefined or reallocated via the local RS232 communication port using the communications program  provided with each System. User defined configurations can also be loaded at the factory previous shipment.

#### Communications

##### Local Port Configuration (RS232C)

Terminal Address

**Not sensitive - enter any number**

Baud rate

**4800 Bauds**

Stop Bits

**1**

Frontal Port Parity

**0 (no parity) - 1 (even parity)**

##### Remote Port Configuration

Terminal Address

**0 - 254 (in steps of 1)**

Baud rate

**300 - 19200 Bauds**

Stop Bits

**1 - 2**

Parity

**0 (no parity) - 1 (even parity)**

- **General Settings**

Terminal Unit In Service	<b>YES/NO</b>
CT Ratio Phase	<b>1-3000</b> (in steps of 1)

- **Breaker Failure Element**

Enable	<b>YES/NO</b>
Pickup 1 (Single Phase)	<b>(1 – 12) A</b> (steps of 0.01 A)
Pickup 2 (Three Phase)	<b>(1 – 12) A</b> (steps of 0.01 A)
Single Phase Time Delay	<b>0.05-1 s</b> (steps of 0.01 s)
Three Phase Time Delay (with overcurrent)	<b>0.05-1 s</b> (steps of 0.01 s)
Three Phase Time Delay (without overcurrent)	<b>0.05-1 s</b> (steps of 0.01 s)

- **History Record**

<b>Average Calculation Time Interval</b>	<b>1-15 min.</b>
<b>Data Record Interval</b>	from <b>1 min.</b> to <b>24.00 h.</b>
<b>Day Calendar Mask</b>	<b>Monday to Sunday (YES/NO)</b>
<b>Hour Range</b>	from <b>0</b> to <b>24.00h.</b>

- **Oscillography (Optional)**

<b>Recording Mode (Fixed Time)</b>	<b>YES/NO</b> <b>YES</b> = fixed time mode <b>NO</b> = variable time mode
------------------------------------	---

<b>Overwrite</b>	<b>YES/NO</b>
------------------	---------------

## Chapter 5

<b>Pickup Type (Register)</b>	<b>Pickup Trip Mode 1 Trip Mode 2</b>
<b>Pre-pickup</b>	<b>1 - 2 cycles</b> (steps of 1)
<b>Oscillography Length</b>	<b>20 - 300 cycles</b> (steps of 1)
<b>Analogic Channels</b>  (* according to model)	<b>0 - 4</b> (five channels) (*)
<b>Pickup Function</b> Breaker Failure Pickup ( <b>ARR</b> ) External Pickup ( <b>EX</b> )	<b>YES/NO</b> <b>YES/NO</b>

## No Keypad Models Settings

Those models without local display and keypad can be programmed using communications ports. There are no access to two settings from **Configuration** group:

<b>Passwords</b> , there are not necessary because there is no keypad	
<b>Operation Enables</b> , default as follows:	
Breaker / Recloser	
Frontal Port	<b>YES</b>
Remote Port	<b>YES</b>
Remote Setting	
Remote Port	<b>YES</b>
Digital Inputs	<b>NO</b>

CHAPTER 6

# Description of Operation

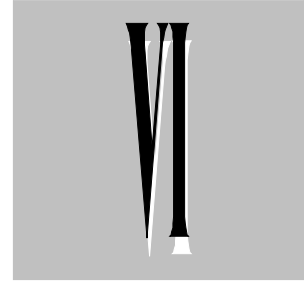

## 6.1 Breaker Failure Unit

The **Breaker Failure** unit detects malfunctions following trip commands and generates a signal to trip other breakers that may be feeding the fault to clear it, that is, to the breakers of the IEDs that are connected to the same protection zone as the IED with breaker failure.

The IED has six **current measuring units**, two per phase. The six pickup detectors are arranged in two groups, providing two different settings: pickup 1 (single-phase pickup) and pickup 2 (three-phase pickup).

The key characteristic of the pickup detectors is their fast reset time (5 ms).

The measuring unit block diagram is shown in Figure 6.1.

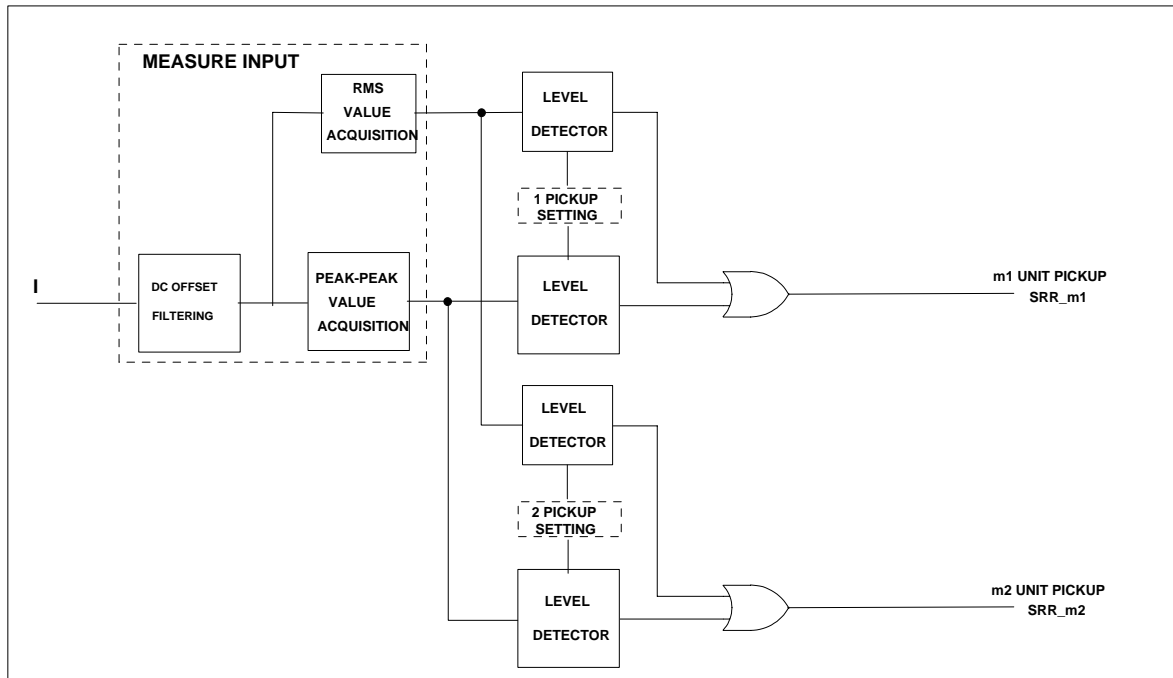

Figure 6.1: Metering Unit Block Diagram.

The breaker failure function is dependent on the pickup of the phase overcurrent units combined with several physical contact inputs, as depicted in Figure 6.2.

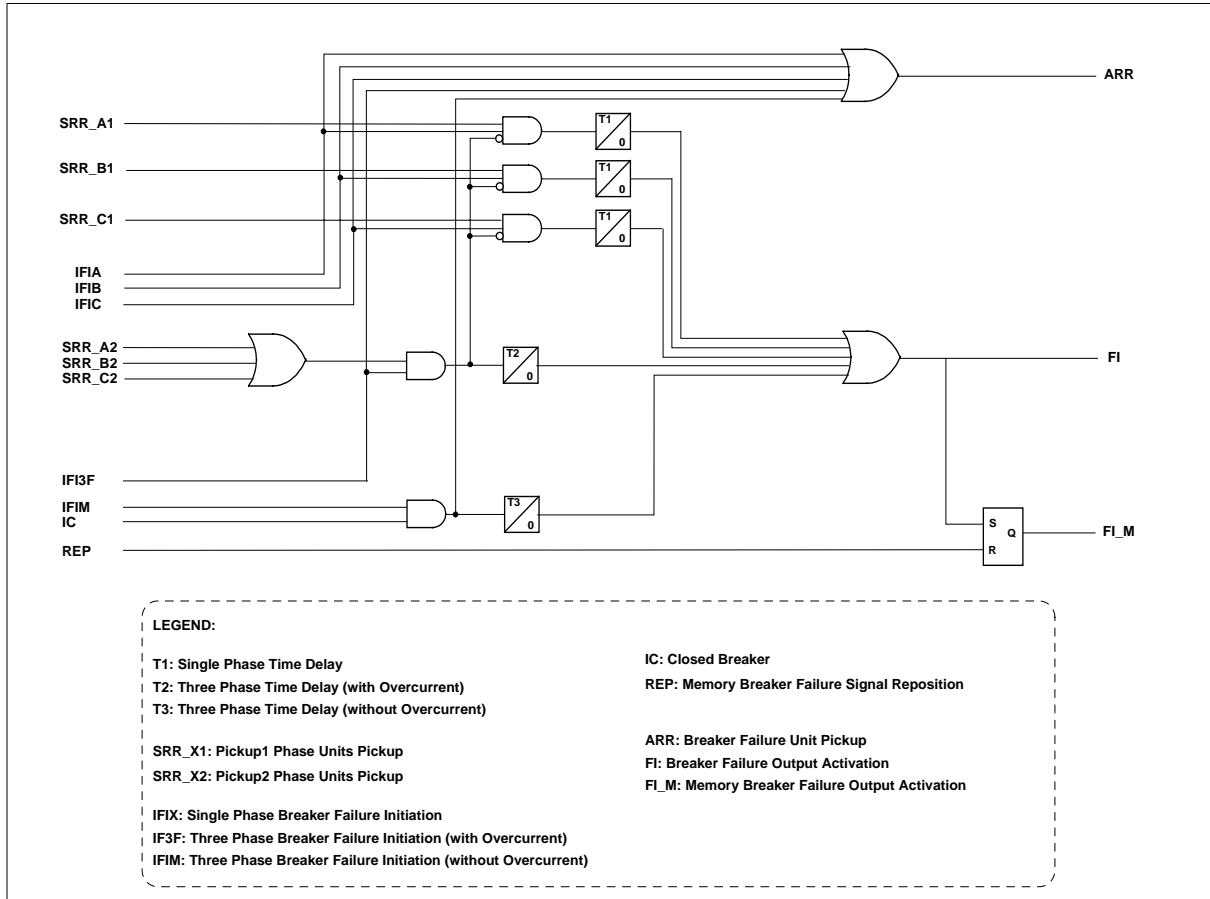

Figure 6.2: Breaker Failure Unit Block Diagram.

The **breaker failure unit** operation can be divided into three groups: **single-phase trip**, **three-phase trip with overcurrent** and **three-phase trip without overcurrent**.

The breaker failure operation (**FI** signal activated), is latched by a bi-stable element, generating the **FI\_M** signal. This signal will remain activated even after **FI** is reset. To reset **FI\_M**, a reset command must be received as a pulse via the digital input associated to **REP**.

### 6.1.1 Single-Phase Trip

After single-phase protection trips, one or more of the digital inputs associated to breaker failure initiate will be active (**IFIA**, **IFIB** o **IFIC**). Since the system is under fault conditions, the current circulating through the faulted phase will exceed the corresponding detector unit setting. These conditions will activate the single-phase breaker failure timer **T1**. If the timer runs out while the **IFI** signal is active, or the faulted phase current detector output is active, the signals **FI** and **FI\_M** will activate. If three-phase trip conditions appear during the timer count, the signals **FI** and **FI\_M** will not activate at timer expiration due to the operation of the single-phase breaker failure.

The key characteristic of the current detectors is their fast reset time, which stops the timer as soon as the breaker opens and the current flow stops to avoid incorrect **FI** activation. Longer reset times risk incorrect tripping of breakers outside the protection zone when current flow is no longer present.

### 6.1.2 Three-Phase Trip with Overcurrent

Three-phase trips, depending on the bay protection, will activate **IFIA**, **IFIB**, **IFIC** inputs or **IFI3F** input only. Breaker failure timer **T2** will start counting. The difference with respect to the single-phase trip operation is that deactivation of all the three current detectors is required to stop the timer. Only one current detector activated after timeout is needed to generate the **FI** and **FI\_M** signals, indicating the breaker failure.

### 6.1.3 Three-Phase Trip without Overcurrent

A three-phase trip without overcurrent will activate the digital input configured with the logic input **IFIM**. If the breaker remains closed, the three-phase trip without overcurrent breaker failure timer **T3** starts counting. If open breaker status and **IFIM** are active after timeout, the signals **FI** and **FI\_M** will activate, as in the cases described above.

## 6.2 Contact Inputs, Outputs and LED Targets

#FIT is provided with programmable inputs, outputs and LED targets enabling user configuration of flexible logic designs.

Logic equations can be created and modified using the  software program.

### 6.2.1 Status Contact Inputs

Several metering units and logic functions can be controlled by the **logic input signals** and any of these logic input signals can be assigned to the available status contact inputs.

The logic input signals are presented in Table 6-1.

It must be remembered that more than one logic input signal can be assigned to a single status contact input, but the same logic input signal can not be assigned to more than one status contact input.

Table 6-1 Inputs		
Num.	Name	Description
1	IFIA	Phase A Breaker Failure Initiate
2	IFIB	Phase B Breaker Failure Initiate
3	IFIC	Phase C Breaker Failure Initiate
4	IFI3F	Three-Phase Trip with Overcurrent Breaker Failure Initiate
5	IFIM	Three-Phase Trip without Overcurrent Breaker Failure Initiate
6	IC	Breaker Position (Closed Breaker)
7	REP	Breaker Failure Reposition Latched
25	INH_C_ED	Setting Group Control Inhibit
26	T_AJ_1	Setting Group #1 Selection
27	T_AJ_2	Setting Group #2 Selection
28	T_AJ_3	Setting Group #3 Selection
31	EX	Oscillography External Activation (*)

(\*) Only for models with Oscillographic Register.

### 6.2.2 Auxiliary Contact Outputs

The #FIT protection and monitoring functions generate a series of logic output signals during operation. Each of these signals has either a “true” or “false” value and this status can be used as an input to either of the combinational logic gates shown in Figure 6.3.

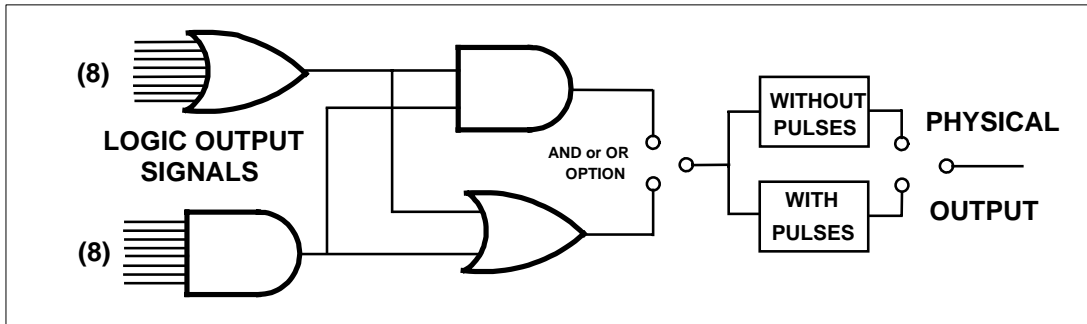

Figure 6.3: Output Logic Block Diagram.

Two blocks of eight inputs are available. One of the blocks performs an **OR** operation with the selected signals (any signal activates the logic gate output). The other block performs an **AND** operation with the selected signals (all signals need to be active to activate the logic gate output). The result of these two blocks is then operated through either an **AND** or an **OR** gate. The pulse option can be added to the result of this operation. It works as follows:

- **Without pulses:** by adjusting the pulse timer to 0, the output signal remains active as long as the signal that activated it lasts.
- **With pulses:** once the output signal is activated, it remains the set time whether or not the signal that generated it is deactivated before or remains active.

There is a no programmable output (AUX-8), that corresponds to “**In Service**”.

Table 6-2 list available logic outputs.

Tabla 6-2 Outputs		
Num.	Name	Description
1	SRR_A1	A1 Unit Pickup
2	SRR_B1	B1 Unit Pickup
3	SRR_C1	C1 Unit Pickup
4	SRR_A2	A2 Unit Pickup
5	SRR_B2	B2 Unit Pickup
6	SRR_C2	C2 Unit Pickup
7	ALARMA_PR	Protection Module Alarm
8	FI	Breaker Failure
9	FI_M	Breaker Failure Latched
10	ARR	Breaker Failure Pickup
11	ALARMA_EN	Alarm detected in the environment module
12	ALARMA_ER	Alarm detected in the error module
13	ENT_FIS_1	Physical Input 1
14	ENT_FIS_2	Physical Input 2
15	ENT_FIS_3	Physical Input 3
16	ENT_FIS_4	Physical Input 4
17	ENT_FIS_5	Physical Input 5
18	ENT_FIS_6	Physical Input 6
19	ENT_FIS_7	Physical Input 7
20	ENT_FIS_8	Physical Input 8

### 6.2.3 LED Targets

#FIT terminals are provided with four optical indicators (**LEDs**) located on the front panel. Three of the **LEDs** are user definable. The fourth **LED** is always assigned to indicate the terminal unit is "**Ready**" (powered up, self-test OK). Each of the configurable **LEDs** is associated with a combinational logic function whose block diagram is represented below in Figure 6.4.

A similar logic cell structure, shown in the block diagram of Figure 6.3 for the outputs, permits the user to create combinational logic equations for the LED Target Outputs, with the difference that at **AND** operation there is only one input.

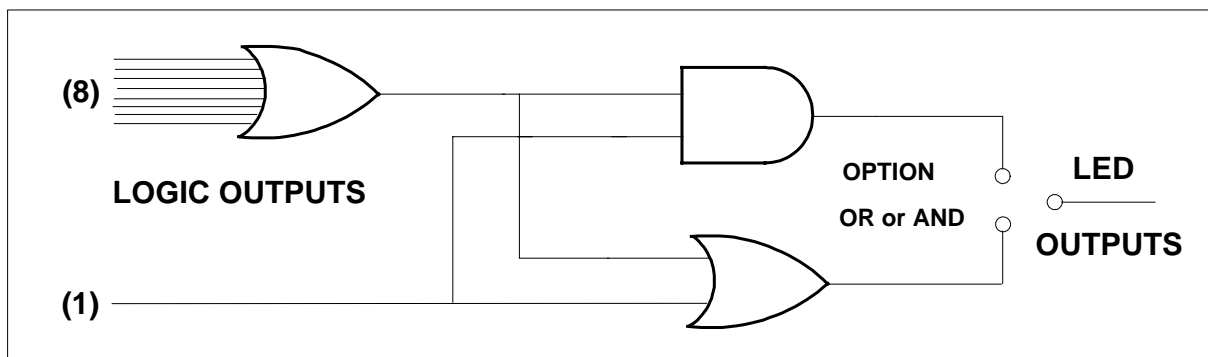



Figure 6.4: LED Target Output Logic Cell Block Diagram.

## Chapter 6

Each indicator can be defined as **latched** or **unlatched**. In the case where the LED is latched, it appears illuminated until reset.

By means of the keypad, (see Chapter 7 Alphanumeric Keypad and Display) the order to reset the LED's can be executed using the key **F2**.

The latching function resides in the volatile memory section of the microprocessor. A power supply loss to the unit will cause any latched LED to reset.

The LED's can be programmed to any of the available logic outputs indicated in table 6-3. The programming of the LED's has been done at the factory, but can be modified by  through a local communications port.

The LED's can be programmed to any of the available logic outputs indicated in Table 6-3.

### 6.3 Setting Group Change

**Protection** Settings are stored in three groups (GROUP1, GROUP2 and GROUP3) which can be activated or deactivated from the keypad or communications port.

The Setting Group Control function allows the user to modify the active Setting Group by means of Status Contact Inputs. This feature enables quick modification of the protection settings when circumstances require a change.

Change of setting group using the communications port or digital input need of a specific enabling by an option in the **configuration** menu of **HMI**. The value of **E\_DIG** should be set to "1" (**YES**) to enable group setting changes to be made from the status contact inputs

When Settings Group Control by Status Contact Inputs is enabled (**E\_DIG** set to "1"), no setting changes can be made from the keypad or the local port. If the **Active group** option on the main menu is selected from the keypad, the display will indicate "**ACCESS DENIED**".

Control setting group by status contact inputs (**E\_DIG** set to "1") and by remote communications port (**P\_REM** set to "1") cannot be enabled simultaneously.

To use this function, three status contact inputs must be programmed to activate the three setting group.

### 6.3.1 Operation

Activation of the inputs, **T\_AJ\_1**, **T\_AJ\_2** and **T\_AJ\_3**, will activate **GROUP 1**, **GROUP 2** and **GROUP 3** respectively. If, while one of the inputs is active, either of the other two or both are activated, no group change will take place.

The status contact settings group control logic will recognize a single input only. If all three inputs are de-energized, the equipment will remain in the last settings group activated.

**NOTE :** the setting group change, activating **T\_AJ\_1**, **T\_AJ\_2** and **T\_AJ\_3**, will be only available if the *display* is at default screen.

### 6.4 Event Record

Each one of the functions that are monitored by the sequence of events portion of the IED are listed in Table 6.1. The functions used by the system are: **Protection, Initialization, Digital Inputs and Command.**

<b>Table 6-3 Event Records</b>			
<b>Funtion</b>	<b>Events</b>	<b>Byte</b>	<b>Bit</b>
<b>Pickups and resets of breaker failure Units: [OC]</b>	C2 Unit Pickup	1	2
	B2 Unit Pickup	1	3
	A2 Unit Pickup	1	4
	C1 Unit Pickup	1	5
	B1 Unit Pickup	1	6
	A1 Unit Pickup	1	7
	C2 Unit Pickup	2	2
	B2 Unit Pickup	2	3
	A2 Unit Pickup	2	4
	C1 Unit Pickup	2	5
	B1 Unit Pickup	2	6
	A1 Unit Pickup	2	7
	<b>Protection Alarm: [11]</b>	PR Alarm Output Activation (Protection Inhabitation)	1
<b>Protection Alarm Deactivation: [12]</b>	PR Alarm Output Deactivation	3	2
	Oscillography Pickup (*) Not generated by fast reposition.	4	2
<b>Inicialization [13]:</b>	Power Up	1	8
	Change of Settings Inicialization	1	7
<b>Inputs [06]:</b>	IN-1 Status Contact Input Activation	1	1
	IN-2 Status Contact Input Activation	1	2
	IN-3 Status Contact Input Activation	1	3
	IN-4 Status Contact Input Activation	1	4
	IN-5 Status Contact Input Activation	1	5
	IN-6 Status Contact Input Activation	1	6
	IN-7 Status Contact Input Activation	1	7
	IN-8 Status Contact Input Activation	1	8
	IN-1 Status Contact Input Deactivation	2	1
	IN-2 Status Contact Input Deactivation	2	2
	IN-3 Status Contact Input Deactivation	2	3

Table 6-3 Event Records (continuation)			
Funtion	Events	Byte	Bit
<b>Inputs [06]:</b>	IN-4 Status Contact Input Deactivation	2	4
	IN-5 Status Contact Input Deactivation	2	5
	IN-6 Status Contact Input Deactivation	2	6
	IN-7 Status Contact Input Deactivation	2	7
	IN-8 Status Contact Input Deactivation	2	8
	IN-1 Status Contact Input Inhabitation	3	1
	IN-2 Status Contact Input Inhabitation	3	2
	IN-3 Status Contact Input Inhabitation	3	3
	IN-4 Status Contact Input Inhabitation	3	4
	IN-5 Status Contact Input Inhabitation	3	5
	IN-6 Status Contact Input Inhabitation	3	6
	IN-7 Status Contact Input Inhabitation	3	7
<b>Command [05]:</b>	Breaker Failure Latched Activation	1	7
	Breaker Failure Activation	1	8
	Breaker Failure Deactivation	2	7
	Breaker Failure Latched Deactivation	2	8
<b>HMI (09)</b>	Group 1 Activation by Status Contact Input	1	1
	Group 2 Activation by Status Contact Input	1	2
	Group 3 Activation by Status Contact Input	1	3
	Local Mode (keypad and display actuation)	1	5
	Remote Mode (rear port actuation)	1	6
	Local Mode (frontal port actuation)	1	7

(\*) only for models with oscillographic register.

The saved information in each of the records includes:

- Phase and Ground current measured at the moment the event was generated
- Event date and time

The event record capacity is one hundred (100) events. When the record is full, a new event displaces the oldest event.

The organization of the record is such that simultaneous events generated by the same function will not occupy separate records, and will use only one position of the event memory. Simultaneous events are those that occur separately within a time interval of 1ms, which is the resolution time of the recorder.

The  communications and remote management software program is used for reading event record information. Information is displayed as shown in Table 6-3.

## 6.5 Current History Record

This function is designed to record the evolution of the electric burden that flows through the point where it is located. It records periodic values of current. The terminal unit samples all three phase currents every second and then calculates an average value for each phase over the interval defined as the **Averaging Calculation Time Interval**. This time interval is adjustable between 1 and 15 minutes. Each interval provides two values of current that corresponds to the highest and the lowest of the three measures carried out on the phases.

At the end of the recording period, called the **Data Record Interval**, which is adjustable between 1 minute and 24 hours, the maximum value retained from each Averaging Calculation Time Interval is entered in the Current History Record.

The available memory for the History Record is the typical RAM, with a capacity corresponding to 168 values (equivalent to 7 days in intervals of 1 hour).

With the goal of adapting the memory use to the application of every user, the **Day Calendar Mask** can be enabled within the defined days (the same interval schedule for all days) in addition to those that do not register a value.

Access to the information about the Current History Record is available through the following sequence: **Information - Records - Current History**. This is explained in Chapter 7, Alphanumeric Keyboard and Display.

Figure 6-5 illustrates an example of a Current History Record.

- **TM**: Sample Interval. The figure shows a value of TM equal to one minute.

- **TR**: Data Record Interval. The figure shows a value of TR equal to 15 minutes.

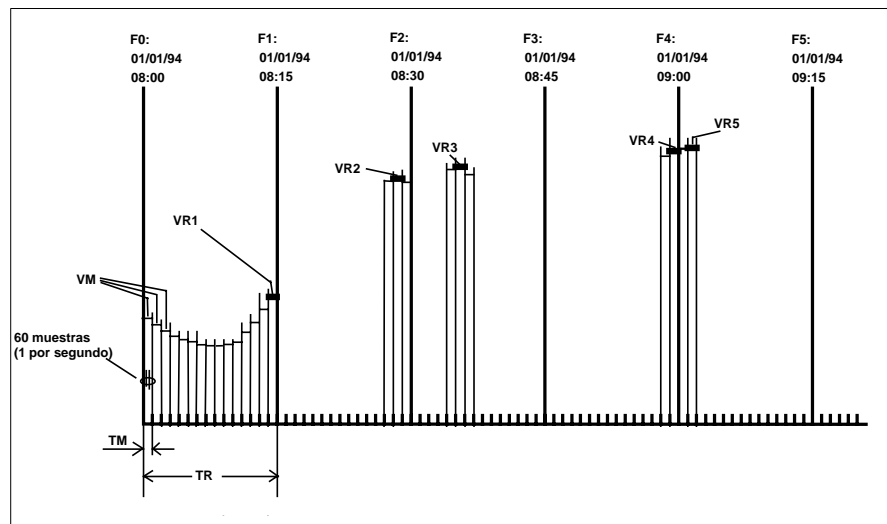

Figure 6.5: Example of Current History Record

Two **VM** values, corresponding to the maximum and minimum average considering the three phase currents are retained for each **TM** time interval. The maximum and minimum of all computed **VM** values is recorded in each **TR** interval. The current profile of the record in Figure 6.5 contains the following data:

VALUE	TIME
VR1	F1
VR2	F2
VR3	F3
VR4	F4
VR5	F5

## 6.6 Oscillography Register (optional)

The **oscillography** is composed of two different functions: **Capture** and **View**. The first refers to the capture and storage of protection data in the terminal unit. Capture is a part of the relay software. View refers to the collection and graphical display of the stored data. This is performed by one or more software programs run by a PC connected to the terminal unit.

### • Capture Function

An analog record is stored each time a sample is taken. Status Contact Input signals are only stored by the Event Record function.

### • Stored Data

The following data is stored with a resolution time equal to the sampling rate:

- **Analog values of the samples selected for recording**
- **Starting time of the oscillography record**

### • Number of Channels

Depending on the model, up to nine new channels can be used, with the ability to activate or deactivate the channels as required with the relevant setting.

### • Recording Mode

The following Recording Modes are selectable: **Fixed Time YES** (Fixed Time Mode) and **Fixed Time NO** (Variable Time Mode).

In the first mode, **Fixed Time YES**, recording begins when the Start function is activated. Recording stops when the pre-determined Record Length set by the user is reached.

In the second Mode, **Fixed Time NO**, recording begins when the Start Function is activated. Recording stops when the Start Function is de-activated.

### • Start Function

The Start Function consists of a programmable mask which can be applied to permit recording to start after selected internal logic output signals or the External Oscillography Start Logic Input Signal. The External Oscillography Start signal can be assigned to any of the physical Status Contact Inputs.

This Start Function Control Mask is connected to each protection element within the relay. Only connections that are enabled by the mask settings will activate the oscillography Start Function. The activation occurs when any of the selected protection elements pick up, and de-activation occurs when all selected elements are reset.

### • Start Time (Pre-Fault Time)

Pre-Fault is the storage time before the activation of the Start Function.

### • Oscillography Record Length

It's defined as the duration time of the store window at the **Fixed Time Mode**.

### • Number of Records

The number of records stored in memory varies and depends on the number of channels recorded and on the length of the fault records.

Once the recording memory is full, the Overwrite setting determines whether or not the next event that occurs is stored over the oldest stored record (s). If the Overwrite setting has been set to **YES** and as the new records vary in length, old records will get canceled depending on the space required by the new record.

### • Start Types

**Pickup:** Recorded data is stored whenever the pickup is activated and continues for a time determined by the Fixed Time Setting and the Record Length.

**Trip 1:** Recorded data, plus pre-fault data, is stored in memory only if a Breaker Failure occurs within the time set for the Record Length for Fixed Time (**YES**) or whenever the pickup function is activated por Fixed Time (**NO**).

**Trip 2:** If no trip occurs within the time set for the Record Length, only 4 cycles of recorded data will be stored after the Start Function is activated

If Fixed Time Setting is (**NO**) and no trip occurs while the pickup remains active, only 4 cycles of recorded data will be stored after the pickup is activated. If a trip occurs while the pickup is active, recorded data will be stored during the whole time the pickup remains active in addition to the pre-fault data.

It is reminded that information recorded during the time set as pre-fault time is always stored.

### • Overwrite

If the Overwrite setting has been set to **NO**, no more records will be stored once the oscillography memory is full. In that situation, set overwrite on **YES** so that new records can get stored.

If the Overwrite setting has been set to **YES**, once the memory is full, the next record will replace the oldest record that is erased.

## 6.7 Communications

### 6.7.1 Communication Settings

Communications settings are listed in Chapter 5 (Settings) and include **terminal unit address**, **baud rate**, **stop bits**, and **parity**.

### 6.7.2 Communications Types



**#FIT** Terminals contain two communications ports. The local port located on the front panel is an RS232 DB-9 port with fixed settings. The remote port is optional, and can be glass fiber optics, 1mm plastic fiber optics, or RS232 type. Technical data relative to these ports is listed in Chapter 2 (Technical Data).

### 6.7.3 Communicating with the Unit

Communications with the unit through the communication ports is achieved using the  software application. This software is designed to connect with units of the **#FIT** family, allowing operations such as programming, settings configuration, event recording, activity reports, etc.

Remote port communication settings can be modified only via the HMI. Local port communication settings are fixed to 4800 baud, 1 stop bit, even parity, as listed in Chapter 5.

**#FIT** models are provided with two communication controllers. This enable simultaneous communications via both ports.

 is password protected to provide access only to authorized personnel.  is a user-friendly, **WINDOWS**<sup>™</sup> based software tool. The software allows easy navigation of and access to available settings and actions through a series of intuitive menus and graphical user interfaces.

## 6.8 Alarm Codes

In the following table are the protection alarm codes and their descriptions. These codes are displayed in the protection display.

<b>Software Alarms</b>	
<b>Code</b>	<b>Description</b>
<b>01 00</b>	Loss of settings
<b>04 00</b>	Check-sum in the RAM zone pertaining to the curves
<b>08 00</b>	Internal communication error
<b>20 00</b>	Internal communication error
<b>40 00</b>	Internal communication error
<b>Hardware Alarms</b>	
<b>Code</b>	<b>Description</b>
<b>00 01</b>	E2PROM writing error
<b>00 06</b>	Internal voltage level error
<b>00 20</b>	E2PROM file calibration error
<b>00 40</b>	RAM file calibration error
<b>00 80</b>	Memory test error

If more than one alarm occurs at the same time, the hexadecimal codes are added as shown below:

<b>01 and 02 = 03</b>	<b>02 and 08 = 0A</b>
<b>01 and 04 = 05</b>	<b>01 and 02 and 08 = 0B</b>
	<b>04 and 08 = 0C</b>
	<b>01 and 04 and 08 = 0D</b>
	<b>02 and 04 and 08 = 0E</b>
	<b>01 and 02 and 04 and 08 = 0F</b>

**Contact with the manufacturer if these alarm codes appear.**

Notes:

CHAPTER 7

# Alphanumeric Keypad and Display



## 7.1 Alphanumeric Display and Keypad

The liquid crystal display has 80 characters (4 rows with 20 characters per row) and displays the alarms, adjustments, measurements, states, etc. There are 4 auxiliary function keys below the display. Figure 7.1 represents the arrangement of the graphic display and the auxiliary function keys.

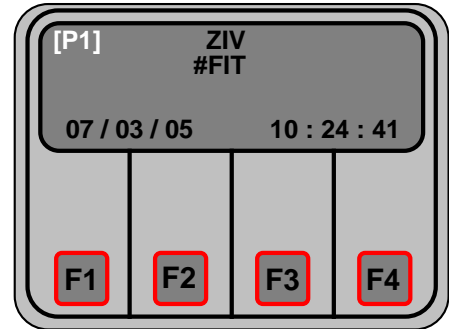

Figure 7.1: Alphanumeric Display.

- **Keypad**

The keypad shows the IED model, date and time. It also shows, on the first row left, the connection mode (if the communication is established) at the following mode:

- [P1] Local connection (communication by frontal port)
- [P2] Remote connection (communication by rear port)

- **Alphanumeric Keypad**

The keypad consists of 16 keys arranged in a 4 x 4 matrix. Figure 7.2 shows the layout of the keypad.

In addition to the keys corresponding to the numbers (keys 0 to 9), there are selection keys (↑ and ↓), the confirmation key (**ENT**), the exit key (**ESC**), and the contrast key (☉). Keeping in mind that in the cases of the **8FIT** models that do not have a keypad, the **HMI** is reduced to only one key, **[R]**, designated to reset the four protection LEDs.

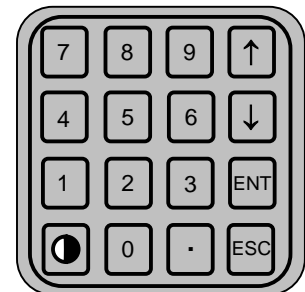

Figure 7.2: Keypad.

The access to the functions can be done by two different modes: using a single key (**F2**) or using the keypad.

## 7.2 Keys, Functions and Operation Modes

The available keypad keys and alphanumeric display keys and their functions are described on the following pages.

- **Keypad**



### Confirmation Key

The **ENT** key is used to confirm an action: after a selection has been made, after editing an adjustment or to move forward the list of records. After finishing an operation (selection, change settings, information, etc.) press **ENT** again to return to the previous screen.



### Escape Key

The key **ESC** is used to exit a screen if the user does not wish to make a modification to the setting or if you merely looked at a screen for information. In either case pressing this system key returns the user to the previous screen.



### Display Selection Keys

The selection keys advance or go backwards, to one of the existing options within a menu or submenu. When there are more than four options within a menu, in the lower right hand corner of the display appears an arrow (↓) indicating the other options. These options can be reached by using the ↓ key, which allows the display of the other options. Appearing then in the upper right hand corner of the display, is an arrow (↑) that indicates the existence of the first options.

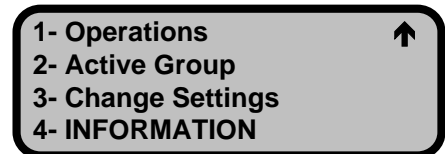

The key ↓ is also used to erase numbers within a setting when making modifications. This function is only needed when changing a setting.



### Contrast Key

Pressing this key adjusts the contrast for the display. The selection keys (↓↑) modify the contrast value: a larger value = less contrast.

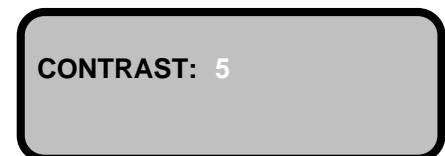

Pressing this key from any menu or submenu also returns the system directly to the default screen.

### • Function Keys

**F1**

Pressing **F1** confirms settings changes (when the equipment asks for confirmation of the changes) or activates the default table of settings.

**F2**

The **F2** key is used to refer to information about the current measurements, voltages and powers, the status of the recloser can be changed, the last trip indication reset, LEDs reset and recloser counters. The entire sequence of actions using Function Key **F2** is explained in the following section.

**F3**

The **F3** key is used to display on the screen information about the event record, and the octets that contain the function codes that the corresponding event has generated.

**F4**

The **F4** key is used to cancel the changed settings (when the equipment asks for confirmation of the changes) and to cancel the activation of the default table of settings. **F4** can, also, be used to reset the terminal.



**A password and confirmation is required before proceeding with the reset function, because all settings could be lost, making the activation of the protection dangerous.**

### **CAUTION**

In the screens corresponding to the fault information, **F4** is used to access the information generated by the trip and the units that tripped to clear the fault.

### • Operation Modes

The numeric keys (from 0 to 9) allow direct access to terminal's settings, information, measurements, etc. This **direct access** consists of pushing successively the identification numbers that are displayed on the screen before each setting, or within a corresponding setting.

Another mode of access consists in going through the menus by the selection keys (↓↑) and confirm the selection option pressing **ENT**.

### • Operation

#### Ratio Settings

The operative value of the setting is at the row of **ACTUAL** word. The new value is introduced at the following row, where there is the **NEW** word.

With the number keys the new value is edited. If an error occurred, the ↓ key erased it. When a new value is edited, press **ENT** to confirm and to go to the previous menu.

There is a setting type which options are **YES** (key 1) or **NO** (key 2). Press **ENT** to confirm and to go to the previous menu.

#### Option Selection Settings

These options can be reached by using the direct number associated or by the selection using ↓ and ↑ keys.

**CT RATIO PHASE**

ACTUAL: 1

NEW:

Range ( 1 to 3000 )

**IN SERVICE**

ACTUAL: YES

NEW:

( 1 - [YES] 0 - [NO] )

**0- FIXED TIME**

1- Inverse

2- Very Inverse

3- Extrem. Inverse

### Menu and Settings Exit

To go out from a menu or setting, press **ESC** key. To go out for an information screen press **ENT** or **ESC**. In all cases the back menu will appear.

## 7.3 Access To Functions Using Key (F2)

The protection functions can be accessed by the **F2** key. Access is available from the default screen or the last trip information screen. Pressing **F2** will cause the display of information in a circular window, allowing access to the following operations:

- Last Trip Indication
- Last Trip Indication Reset
- Phase current measurements
- LED's Reset

### 7.3.1 Last Trip Indication

If a trip has occurred, the screen displays the associated elements. This information will displays as follows:

This screen displays the date and time of the fault indication until that indication be reset. This can be done from the trip indication reset screen "**RST TRIP INDICATION**" of the **F2** associated menu.

**BREAKER FAILURE  
ACTUATION**

07/03/0516:20:48

### 7.3.2 Screen Sequences using F2

If the screen sequences starts, the return to the default screen or last trip indicated screen only will be possible if the cycle ends.

- **Measurements**

Pressing **F2** from default or last trip indication screen, measurements screen is displayed, showing currents values.

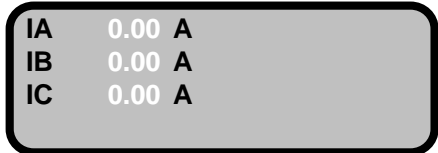

- **Trip Indication Reset**

Pressing **F2** again the trip indication reset screen appears.

To continue without resetting the indication, press **F2** to access the LEDs reset screen. On the contrary, pressing the **F2** during 2 seconds, executes the order, and a message appears on the screen saying **INDICATION RESET**.

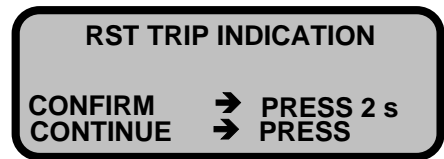

- **LEDs Reset**

Pressing **F2** again **LEDs** reset screen appears. If the order is executed all the LEDs will light and this message will appear on the screen: **LEDs ACTIVATED**.

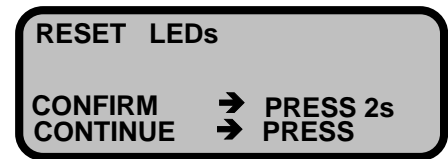

Pressing again **F2** the cycle can be repeat. The system automatically returns to the default screen if no keys entries are made after 20 seconds.

## 7.4 Function Access Using the Keypad

From the default screen or the trip / reclose screen, pressing any key on the keypad displays the Main Menu. The main menu has a series of sub-menus associated with it. The following figures presents the menu maps corresponding to:

- **Configuration**
- **Operations**

- **Change Settings**
- **Information**

The access to the protection functions has two possible operation modes: using the selection keys (↓↑) and confirming with **ENT**, or directly pressing at keypad the associated number.

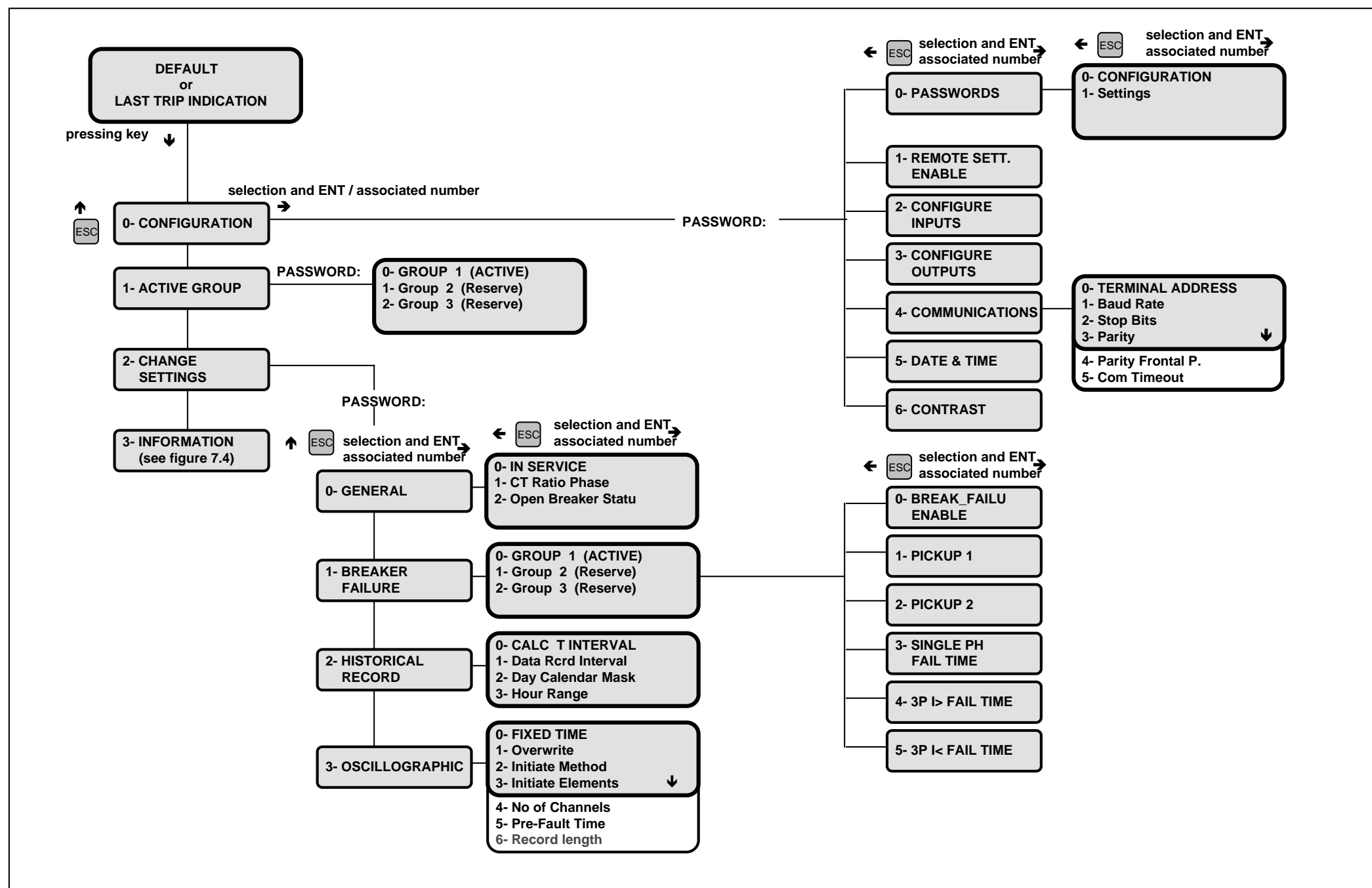

Figure 7.3: Operator Interface Menu Architecture (Configuration, Operations, and Settings)

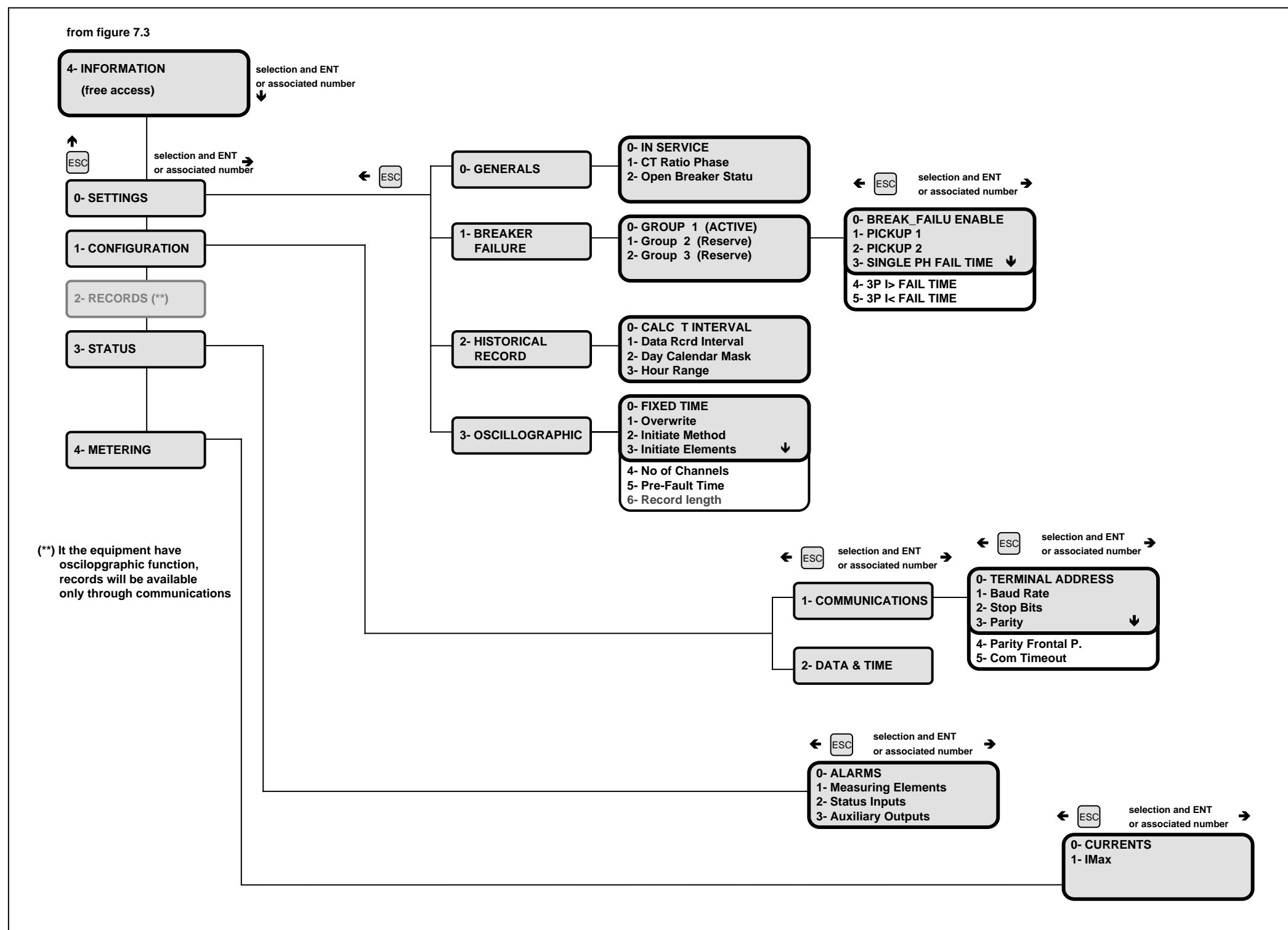

Figure 7.4: Information Menu Architecture

CHAPTER 8

# Receiving Test



## 8.1 General

Improper handling of electrical equipment is extremely dangerous, therefore, only skilled and qualified personnel familiar with appropriate safety procedures and precautions should work with this equipment. Damage to equipment and injury to personnel can result when proper safety precautions are not followed.

The following general safety precautions are provided as a reminder:

- High magnitude voltages are present in auxiliary supply and metering circuits **even after equipment has been disconnected**.
- Equipment should be solidly **grounded** before handling or operating.
- Under no circumstances should the operating **limits of the equipment** be exceeded (auxiliary voltage, current, etc.).
- **The auxiliary supply voltage (AC or DC) should be disconnected from the equipment** before extracting or inserting any module, otherwise damage may result.

The number, the type and the specific characteristics of the acceptance tests are model dependent and are detailed in the following table.

<b>#FIT</b>	Preliminar Inspection
	Isolation Test
	Power Supply Test
	Metering Test
	Breaker Failure Unit Test
	Status Contact Inputs and LEDs Supervision Test
	Communications Test

### 8.1.1 Accuracy

The results obtained in electrical testing greatly depend on the accuracy of the measuring instruments and test source signals (power supply voltage, ac currents, and ac voltages). Verification of the information specified in the Technical Characteristics portion of the manual can only be achieved using test equipment in nominal reference conditions with tolerances as specified in the standards **UNE 21-136 and CEI 255**.

The absence of harmonics (according to the rule <2% distortion) is particularly important since they can affect the internal measurement of the equipment. For example, if we indicate that this equipment is made of non-linear elements, you will see a difference in 1Aac before the existence of harmonics, and after. The measurement differs between cases.

To make the accuracy more precise we realize, the test will depend as much on the instruments used for the measuring as the sources used. Therefore, the tests done for secondary equipment are useful simply for comparison of the equipment's function and not its accuracy.

## 8.2 Preliminary Inspection

Examine the following aspects to conduct the preliminary inspection:

- The relay is found in perfect physical condition, all of the parts are securely attached and no assembly fasteners are missing.
- The model numbers and specifications agree with the equipment order.

## 8.3 Isolation Test

During isolation tests, if the integrity of the external cable harness is to be checked, remove the connectors from the equipment. This will avoid possible damage to the connectors if the test is not performed properly or if a short exists in the harness. Insulation tests have already been performed at the factory.

### • Common Mode

Short-circuit all of the terminals of the unit except the 83 (84) at **3FID's** and C1 at **8FID's**. Also the ground terminal of the casing should be disconnected. Then apply 2,000 Vac, during 1 min., between the interconnected terminals and metal case.

### • Transverse Mode

The isolation groups are formed for the current inputs, status contact inputs, auxiliary outputs, trip contacts and power supply. Depending on the model, the groups are formed as indicated in Table 8-1. Then apply 2,000 Vac, during 1 min., between the following groups.

Table 8-1		
	3FIT	8FIT
<b>Channels</b>	(1-2) (3-4) (5-6)	(A1-A2) (A3-A4) (A5-A6)
<b>Status Contact Inputs</b>	(67-68-69-70-71-72-73-74-75-76-77-78-22-24-30-32-65-66)	(B7-B8-B9-B10-B11-B12-B13-B14-B15-B16-B17-B18-B19-B20-B21-B22-B23-B24)
<b>Trip Contacts</b>	(21-23-25-26-27) (29-31-33-35)	(C7-C8-C9-C10) (C11-C12-C13-C14)
<b>Auxiliary Outputs</b>	(37-39-41-43-45-47-48-49-50-51-52-53-54-55-57-58-59-61-62-63)	(C4-C5-C6-C17-C18-C19-C20-C21-C22-C23-C24-B3-B2-B1-B6-B5-B4-C15-C16)
<b>Power Supply</b>	(79-80-81-82)	(C2-C3)

**Internal capacitors exist that can generate a high voltage if you take away the isolation test probes without lowering the test voltage.**

## 8.4 Power Supply Test

Connect the power supply as indicated in the following table.

Model	VCC PROT	CON1P	CON2P
3FIT	79(+)-81(-)	41-37	41-39
8FIT	C3(+)-C2(-)	C6-C4	C6-C5

Test that when the equipment is found without power, the contacts designated by CON2P in the table above are closed and the contacts designated by CON1P are open. Apply nominal power test to see that the state of the contacts for CON1P and CON2P change and that the LED “**available**” is on.

## 8.5 Current Metering Test

For this test, prevent interrupting the current injection from the breaker to prevent tripping the equipment. The metering performed by the equipment should be within the following margins:

Table 8-2	
Applied Current	Measured Value
X	$X \pm 5\%$

## 8.6 Breaker Failure Test

### One-phase tripping

Set the pickup-1 value as 1A and the pickup-2 value as 10A.

Activate the digital input configured as **IFIA** (Phase A Breaker Failure Initiate). Now, apply 2A in phase A and check the activation of the BF contact. Delete the configuration for the digital input and check the BF unit is reset.

Repeat the same operations for phases B and C by setting the digital input as required (**IFIB** for phase B and **IFIC** for phase C).

### Three-phase tripping under overcurrent conditions

Set the pickup-1 value as 10A and the pickup-2 value as 1A.

Activate the digital input configured as **IFI3F** (Three phase Trip with Overcurrent Breaker Failure Initiate). Now, apply 2A in phase A and check the activation of the BF contact. Delete the configuration for the digital input and check the BF unit is reset.

Repeat the same operations for phases B and C with the digital input configured in the same way: **IFI3F**.

- **Three-phase tripping under no-overcurrent conditions**

Check that by activating both digital inputs: **IFIM** (Three phase Trip without Overcurrent Breaker Failure Initiate) and **IC** (Breaker position-Breaker closed) with no current injection, the BF indication is activated without any pick-up indication before.

- **Breaker Failure indication reset**

Activate the digital input configured as **REP** (Breaker Failure Reposition Latched) and check that the BF indication output is reset.

### 8.6.1 Timers

Set the pickup-1 and the pickup-2 values as 5A and the three available timers (one-phase, three-phase under overcurrent conditions and three-phase under no-overcurrent conditions) as 0.2s, 0.5s and 1.0s respectively.

- Apply 6A in phase A and activate the digital input configured as **IFIA**.  
Check that the BF indication happens between 0.19s and 0.21s. Finally, deactivate the digital input.
- Apply 6A in phases A, B and C and activate the digital input configured as **IFI3F**.  
Check that the BF indication happens between 0.475s and 0.525s. Finally, deactivate the digital input.
- Activate both digital inputs configured as **IFIM** and **IC**.  
Check that the BF indication happens between 0.95s and 1.05s.

## 8.7 Status Contact Inputs and LEDs Supervision Test

Turn off and power up the relay to its rated voltage again. The "**available**" LED should illuminate now.

Keep pressing the **F2** key until the "**RESET LEADS**" option appears in the *display*. Hold it down until all the LEDs are lit. Release the key and check that all the LEDs go off.

Apply the rated voltage of the inputs between the terminals:

- **8FIT Model**  
(B7-B8) (B9-B10) (B11-B12) (B13-B14) (B15-B16) (B17-B18) (B19-B20) (B21-B22)  
with negative polarity on terminals:  
B8, B10, B12, B14, B16, B18, B20 and B22
- **3FIT Model**  
(67-68) (69-70) (71-72) (73-74) (75-76) (77-78) (22-24) (30-32)  
with negative polarity on terminals:  
68, 70, 72, 74, 76, 78, 24 and 32

## 8.8 Communication Test

To carry out the communication test, it is necessary to supply the equipment with its rated voltage value and the **In Service** LED should then be switched on.

Test will be performed through local communications port, allocated on front panel. This port has the fixed settings that follow:

Baud rate	<b>4800 Bauds</b>
Stop Bits	<b>1</b>
Parity	<b>1 (even parity)</b>

Connect to the terminal unit through the local communications port using a DB9 (9-pin) serial connection wire. Synchronize time using the  software program. Disconnect the communications wire and disconnect the terminal unit power supply and wait for two minutes.

Afterwards, connect the power supply and connect to the terminal unit through the remote communications port. Activate the “cyclical” mode in the  software program and verify that time actualizes properly.

## 8.9 Installation

### Location

The location where the Terminal Unit is to be installed should meet the following minimum conditions to ensure correct operation, long service life, ease of installation and ease of maintenance:

- Absence of dust
- Absence of dampness
- Absence of vibration
- Adequate lighting
- Easy access

Mounting should be in accordance with the instructions regarding installations in the dimension diagram (at the end of this Instruction Manual).

### • Connection

Terminal 83 (or 84) for the **3FIT** or C1 for **8FIT** should be solidly grounded to ensure disturbance filtering circuits operate properly. The wire used for grounding these terminals should be stranded 14 AWG. Ground wire length should be minimized and should not exceed 12". The ground terminal of the enclosure located on the rear panel of the equipment should also be grounded.

CHAPTER 9

# Figures

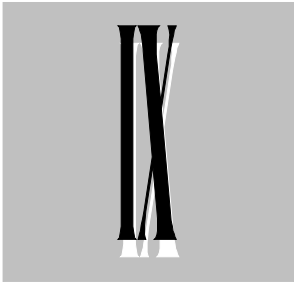

## Chapter 9

Figure	page
1.1 Model Selection .....	1-4
4.1 ¼ Rack 3FIT Front View Front View .....	4-2
4.2 8FIT Front View (2U x 19" Rack) .....	4-3
4.3 8FIT (without a Keypad) Front View (2U x 19" Rack) .....	4-3
4.4 Rear View of a 3FIT of ¼ Rack .....	4-4
4.5 Rear View of an 8IFT (2 Racks Unit High) .....	4-5
6.1 Metering Unit Block Diagram .....	6-2
6.2 Breaker failure Unit Block Diagram .....	6-3
6.3 Output Logic Block Diagram .....	6-6
6.4 LED Target Output Logic Cell Block Diagram .....	6-7
6.5 Example of Current History Record .....	6-11
7.1 Alphanumeric Display .....	7-2
7.2 Keypad .....	7-2
7.3 Operator Interface Menu Architecture (Configuration, Operations and Settings) .....	7-7
7.4 Information Menu Architecture .....	7-8

# Schemes and Drawings

The following plans are attached

**Dimension and drill hole schemes**

3FIT (6U x ¼ rack)	>>	4BF0100/0004
8FIT (2U x 1 rack)	>>	4BF0100/0011

**External connection schemes**

3FIT	>>	3RX0104/0004
8FIT	>>	3RX0145/0003

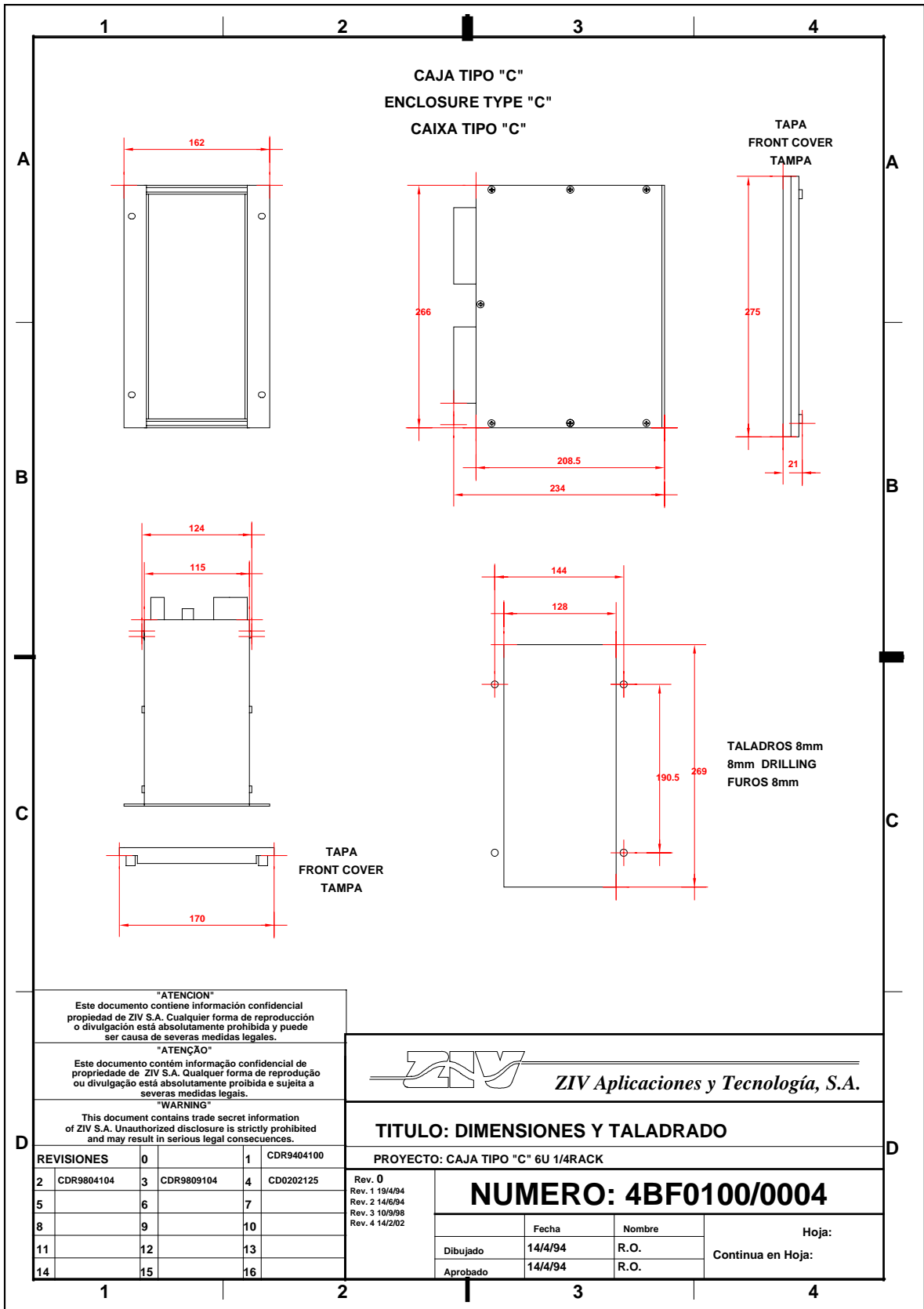

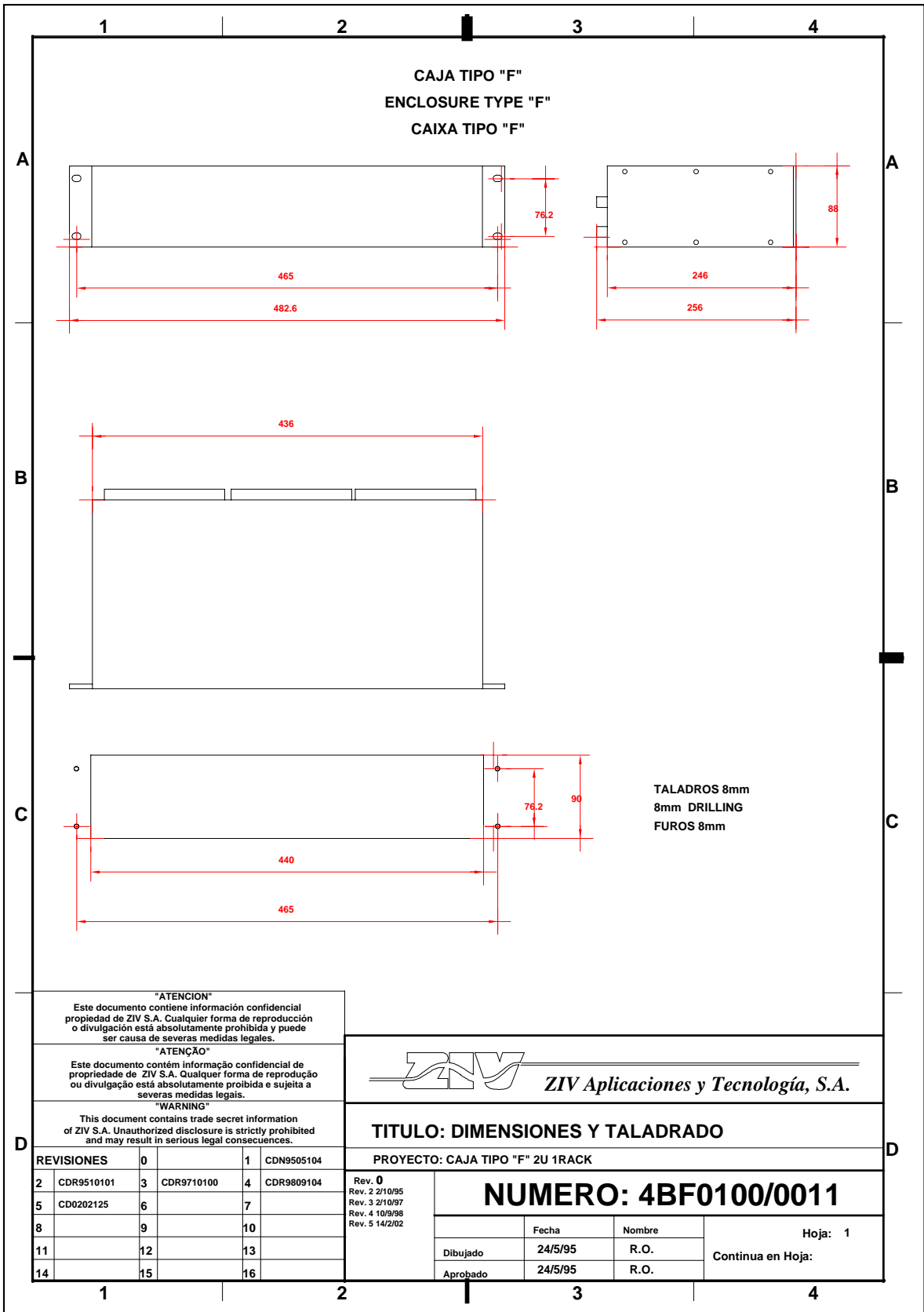

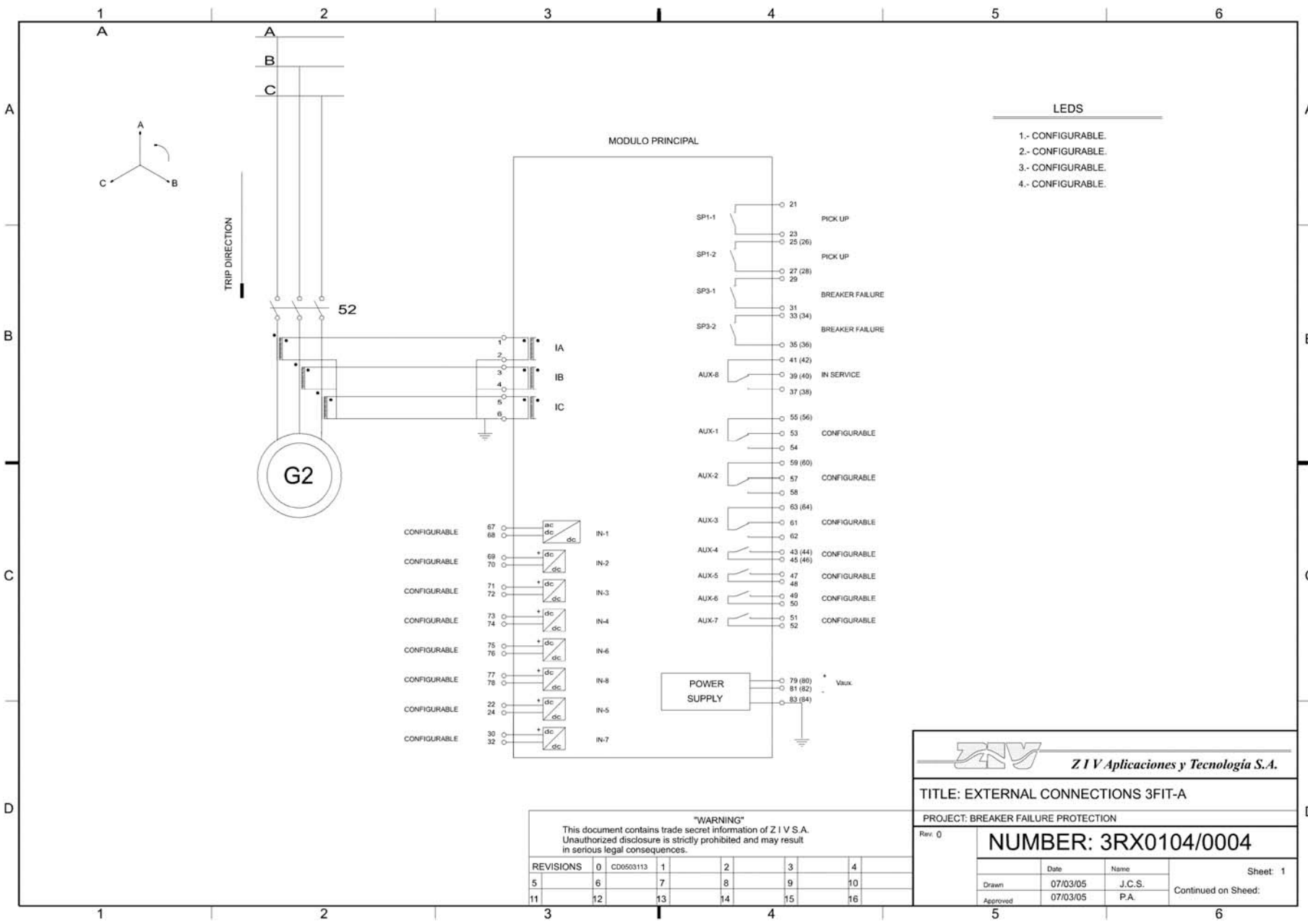

- LEDS**
- 1.- CONFIGURABLE.
  - 2.- CONFIGURABLE.
  - 3.- CONFIGURABLE.
  - 4.- CONFIGURABLE.

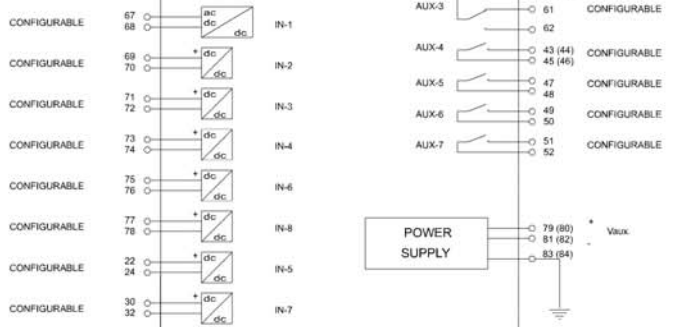

**ZIV Aplicaciones y Tecnología S.A.**

**TITLE: EXTERNAL CONNECTIONS 3FIT-A**

**PROJECT: BREAKER FAILURE PROTECTION**

Rev: 0

NUMBER: 3RX0104/0004

Date	Name	Sheet: 1
07/03/05	J.C.S.	
07/03/05	P.A.	

Continued on Sheed:

**"WARNING"**  
This document contains trade secret information of Z I V S.A.  
Unauthorized disclosure is strictly prohibited and may result  
in serious legal consequences.

REVISIONS	0	1	2	3	4
5	6	7	8	9	10
11	12	13	14	15	16

1 2 3 4 5 6

A

B

C

D

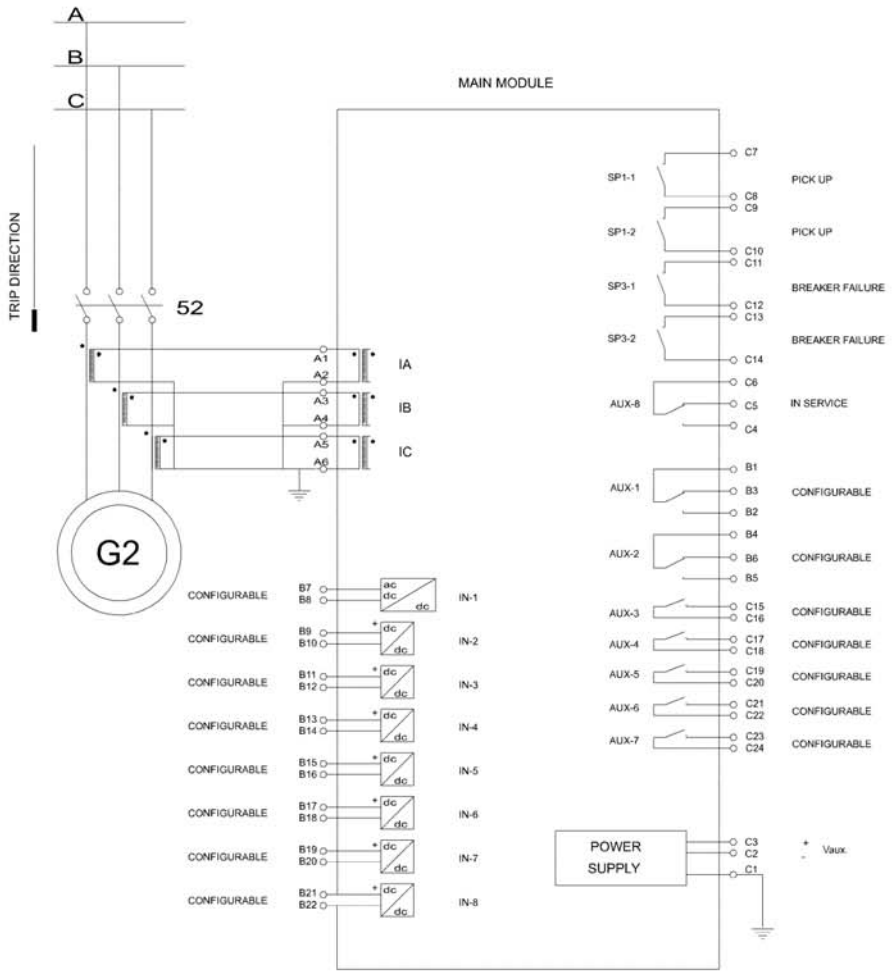
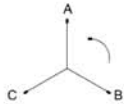

**LEDS**

- 1.- CONFIGURABLE.
- 2.- CONFIGURABLE.
- 3.- CONFIGURABLE.
- 4.- CONFIGURABLE.



**ZIV Aplicaciones y Tecnología S.A.**

**TITLE: EXTERNAL CONNECTIONS 8FIT-A**

PROJECT: BREAKER FAILURE PROTECTION

Rev. 0

**NUMBER: 3RX0145/0003**

**"WARNING"**  
 This document contains trade secret information of Z I V S.A.  
 Unauthorized disclosure is strictly prohibited and may result  
 in serious legal consequences.

REVISIONS	0	1	2	3	4
	CD0503113				
5	6	7	8	9	10
11	12	13	14	15	16

Date	Name
07/03/05	J.C.S.
07/03/05	P.A.

Sheet: 1

Continued on Sheed:

1 2 3 4 5 6

ANNEX A

**Protection  
Communications  
Protocol  
PROCOME 3.0**

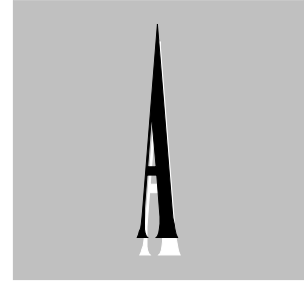

## Model-specific documentation with protection communications protocol PROCOME 3.0

### A.1 Settings

- Configuration Settings

Communications password enable (*)	YES / NO
Communications password timeout (*)	1 - 1440 min
Communications password (*)	8 characters

(\*)Settings for establishing communication through the remote port

- Logic Settings

Pickup report	YES / NO
---------------	----------

- Historical

Log startup time	00.00 - 24.00
Log end time	00.00 - 24.00

## A.2 Description of Operation

### A.2.1 General Settings

- **Event Masks**

If the communications protocol defined for protection is **PROCOME 3.0**, the activation / deactivation events of the directional elements will be masked by default.

If the directional elements are not in a stable situation they should not be unmasked. In the specific case of the neutral directional, it should not be unmasked unless it is to analyze some very specific situation.

### A.2.2 Pickup Report

The **Fault Report** is constructed as follows: it commences when a pickup occurs and ends when the units are reset. The fault report file only makes an annotation if a trip occurs in the course of the fault.

The **Pickup Report** setting allows selecting the option to make an annotation in the file without a trip occurring. When the setting takes the value **YES**, the corresponding report is registered in the fault report file without the need of a trip occurring.

### A.2.3 Event Record

Table A-1: Event Record			
function	event	byte	bit
33750	Measurement Annotation	1	1

- **Organization of the Event Record**

As stated above, if the communications protocol defined for protection is **PROCOME 3.0**, the activation / deactivation events of the directional elements will be masked by default.

If the directional elements are not in a stable situation they should not be unmasked. In the particular case of the neutral directional, it should not be unmasked unless it is to analyze some very specific situation.

## A.2.4 Fault Report

- **Via Communications**

**Fault initiation time tag.** It presents the date and time corresponding to the point in time in which the pickup of the first unit involved in the fault occurs. It also includes:

- **Pre-fault magnitudes:**

**Currents** (modules and arguments) of the currents of the three phases and of the neutral two cycles before the initiation of the fault. The arguments refer to phase A of pre-fault voltages.

**Voltages** (modules and arguments) of the three phases two cycles before the initiation of the fault.

**Trip command time tag,** presenting the date and time of the trip command. It also presents:

- **Fault magnitudes**

**Currents** (modules and arguments) two cycles and a half after the initiation of the fault. The arguments refer to phase A of pre-fault voltages.

**Voltages** (modules and arguments) two cycles and a half after the initiation of the fault.

## A.2.5 Inputs

There exists the possibility of the physical inputs functioning with inverse logic, assigning one or a set of them to a status contact input or to its negated.

## A.2.6 Communicating with the Unit

Using the **PROCOME** profile, it is possible to communicate with the unit to request control changes and to execute orders. In this case, the distance to the fault calculated by the locator is transmitted as one more measurement.

## A.3 Alphanumeric Keyboard and Display

### A.3.1 Communications

Selecting the communications option brings up a menu composed of the settings: **terminal address**, **baud rate**, **stop bits**, **parity**, **communications password enable**, **communications password timeout** and **communications password**.

### A.3.2 Settings

#### A.3.2.a Logic Settings

From the change settings menu, select the option **logic** to view the screen for selecting tables.

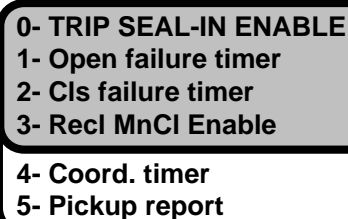

0- TRIP SEAL-IN ENABLE  
 1- Open failure timer  
 2- Cls failure timer  
 3- Recl MnCl Enable ↓  
 4- Coord. timer  
 5- Pickup report

- **Pickup Report**

The construction of the fault report commences when a pickup occurs and ends when the units are reset. An annotation is made in the fault report file when there has been a trip in the course of the fault. When this setting takes the value **YES**, annotations will be made in the report whether there is a trip not.

#### A.3.2.b Historical

The options of the historical menu are the following: **window for calculating averages**, **record interval**, **days of the week mask**, **log startup time** and **log end time**.



0- CALC T INTERVAL  
 1- Data Rcrd Interval  
 2- Day Calendar Mask  
 3- Hist Hour Ini ↓  
 4- Hist Hour Fin

- **Log Startup and End Times**

These two settings define the interval for recording values within the days defined in the days of the week mask setting.

Outside this interval marked by the log startup and end times, no value will be recorded.

### A.3.3 Accessing the information

The variations in the settings menus described in the preceding sections are reflected in the information menus, with the same layout shown. Note that the information menu only allows viewing the established settings and does not allow modifying them.

Notes:

ANNEX B

**DNP 3.0**  
**Protocol**

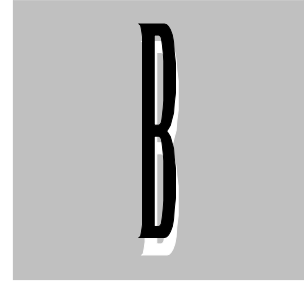

## Documentación específica de los modelos con PROTOCOLO DNP 3.0

### B.1 Physical Architecture

Figure B.1 shows de option, for the **8FIT** model, of a communication rear port.

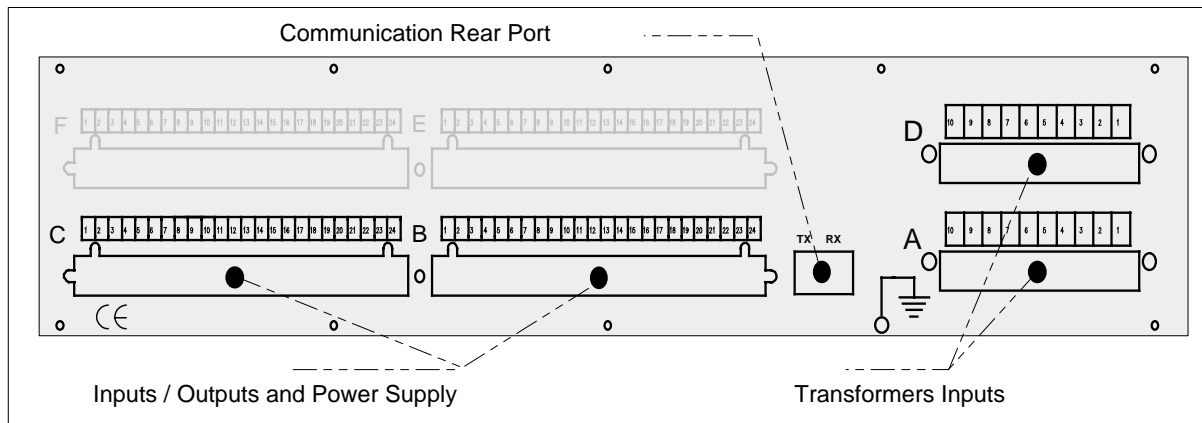

Figure B.1: Rear View of an 8FIT with a Communication Port.

### B.2 Settings

#### • DNP 3.0 Protocol Settings

##### DNP Configuration

MTU Address (Master equipment number)	<b>0 – 65519</b> (steps of 1)
RTU Address (Slave equipment number)	<b>0 – 65519</b> (steps of 1)
Unsolicited Report	<b>0 – 1</b>
Reply Timeout N7	<b>100 – 65535 ms</b> (steps of 1 ms)
Unsol Delay Report	<b>100 – 65535</b> (steps of 1 ms)
N7 Retry Counter	<b>0 – without retries</b> <b>1 – one retry</b> <b>2 – two retries</b> <b>3 – three retries</b> <b>4 – infinites retries</b>
Pre-transmission Time	<b>0 – 65535 ms</b> (steps of 1 ms)
Echo Control Enable	<b>0 – 1</b>
N2 Retries	<b>0 - 32</b> (steps of 1)
Fixed Delay	<b>0 – 32767</b> (steps of 1 ms)
Max. Random Delay	<b>0 – 32767</b> (steps of 1 ms)

**Metering Changes Settings**

Settings independents for metering changes from 0 to 15

% Change metering	<b>0.00 - 100 %</b> (in steps of 0,01 %)
-------------------	--

## B.3 Description of operation

### B.3.1 DNP 3.0 Protocol

The models with the option DNP 3.0 communication protocol present the following configuration settings:

- **DNP Configuration Settings**

The DNP 3.0 protocol configuration settings incorporate the definition of the **RTU** and **MTU** address (number of slave equipment and number of master equipment); the activation or deactivation of **unsolicited**, the setting of **Reply Timeout N7**, which fixes the time out to receive confirmation from the master asked by the slave with CON bit set to 1, the number of **new attempts** which can be applied when waiting for confirmation from the master, if it does not arrive repeatedly within the time fixed by the Time out N7, the setting for the **warning time setting**, time which generates the number of warning characters, and the one of **echo control**, i. e. the activation or deactivation of the transmission echo.

**Note:** warning time and echo control settings are used to have various equipments connected to a concentrator type CCY and working in multi-master mode.

- **Metering Changes (Deadband Values)**

Analog metering bands (according to equipment and model) can be set. The setting represents the percentage over the maximum value of the measure, that will be taken as reference to test if there is an analogical change to record. In other word, a change will be recorded if the difference in the analogical measures is greater than the set percentage.

If it is adjusted to 100%, analogical changes in this measure will not be recorded, which is then understood as being in a deactivated state.

## Annex B

### • Implementation table

OBJECT			REQUEST (#IDN will parse)		RESPONSE (#IDN will respond)		Notes
Obj	Var	Description	Func Codes (dec)	Qual Codes (hex)	Func Codes (dec)	Qual Codes (hex)	
1	0	Binary Input – All variations	1	0x6			
1	1	Binary Input			129	0x1	Assigned to Class 0
2	0	Binary Input Change – All variations	1	0x6,7,8			
2	1	Binary Input Change without Time	1	0x6,7,8			B
2	2	Binary Input Change with Time	1	0x6,7,8	129,130	0x28	Assigned to Class 1
2	3	Binary Input Change with Relative Time	1	0x6,7,8			B
10	0	Binary Outputs – All variations	1	6			A
12	1	Control Relay Output Block	3,4,5,6	0x17,28	129	Echo of request	
20	0	Binary Counter – All variations	1	0x6			A
21	0	Frozen Counter – All variations	1	0x6			A
22	0	Counter Change Event – All variations	1	0x6,7,8			B
30	0	Analog Input – All variations	1	0x6			
30	2	16-Bit Analog Input			129	1	Assigned to Class 0
32	0	Analog Change Event – All variations	1	0x6,7,8			
32	4	16-Bit Analog Change Event with Time			129,130	0x28	Assigned to Class 2
40	0	Analog Output Status – All variations	1	0x6			A
41	2	16-Bit Analog Output Block	3,4,5,6	0x17,28			A
50	1	Time and Date	2	0x7 count=1	129		C
52	2	Time Delay Fine	23		129	0x7 count=1	F,G

OBJECT			REQUEST (#IDN will parse)		RESPONSE (#IDN will respond)		
Obj	Var	Description	Func Codes (dec)	Qual Codes (hex)	Func Codes (dec)	Qual Codes (hex)	Notes
60	1	Class 0 Data	1	0x6	129	0x01	
60	2	Class 1 Data	1	0x6,7,8	129	0x28	D
			20,21	0x6			
60	3	Class 2 Data	1	0x6,7,8	129	0x28	D
			20,21	0x6			
60	4	Class 3 Data	1	0x6,7,8			B
80	1	Internal Indications	2	0x0 index=7			E
--	--	No Object (Cold Start)	13				F
--	--	No Object (Warm Start)	14				F
--	--	No Object (Delay Measurement)	23				G

**Notas:**

**A:** El nivel de implementación del equipo no soporta este grupo y variación del objeto o, para objetos estáticos, no tiene objetos con este grupo y variación. Respuesta **OBJECT UNKNOWN** (IIN2 bit 1 activo).

**B:** No se especifica ningún rango de puntos, y el equipo no tiene objetos de este tipo. Respuesta **NULL** (ningún bit IIN activo, únicamente no se responde a ningún objeto del tipo especificado).

**C:** El equipo soporta operaciones de escritura sobre objetos "Time and Date". El bit "Time Synchronization-Required Internal Indication" (IIN1-4) se pondrá a cero en la respuesta.

**D:** El equipo puede ser configurado para enviar o no, respuestas no solicitadas (unsolicited responses). Existe una opción de configuración accesible a través del **MMI** (Man-Machine Interface or front-panel user interface). Una vez activada la opción Unsolicited, el Master puede habilitar o deshabilitar los mensajes Unsolicited (para Clases 1 y 2) mediante requests (FC 20 y 21). Si el modo de respuesta Unsolicited se habilita, entonces después del reinicio del equipo, éste transmitirá una inicial respuesta no solicitada **NULL**, solicitando una confirmación de la capa de aplicación. Mientras se espera la confirmación de la capa de aplicación, el equipo responderá a todas funciones de petición, incluidas las peticiones de LECTURA (READ requests).

**E:** El bit "Restart Internal Indication" (IIN1-7) puede ser explícitamente puesto a cero por el master.

**F:** La estación remota, después de recibir una petición **Cold or Warm Start**, responderá enviando un mensaje "Time Delay Fine object" (el cual especifica un intervalo de tiempo hasta que la estación remota estará preparada para más comunicaciones), reiniciando el bit de proceso y ajuste DNP IIN1-7 bit (Device Restart).

**G:** El equipo soporta peticiones "Delay Measurement" (FC = 23). Responde con el objeto "Time Delay Fine object" (52-2). Este objeto establece el número de milisegundos transcurridos entre la recepción por parte de la estación remota del primer bit del primer byte de la petición y el tiempo de transmisión del primer bit del primer byte de la respuesta.

## Annex B

### Specific characteristics of the unit

- There is a "Time window" ("Delay of Unsolicited Request" setting) between the generation of an event and the subsequent transmission of the *unsolicited* message. This is done to group various events in a message and save bandwidth.

- Internal Indication IIN1-6 (Device trouble): It activates to indicate a change in the current DNP configuration of the remote station. It deactivates in the next response. It is used to let the master station know that the DNP settings have changed in the remote station. Note that some erroneous configurations could render it impossible to communicate this condition to a master station.

This "Device Profile Document" also declares the DNP 3.0 settings available in the unit. If the user changes any of these settings, the "Device Trouble Internal Indication" bit will activate in the next response sent.

- Event Files: the unit can store up to 50 "Binary Input Changes" and 50 "Analog Input Changes." If the unit's limits are reached, the "Event Buffers Overflow Internal Indication" bit will be enabled in the next response sent. It will be disabled when the master reads the changes, making room for new ones.

- The measurements (16-Bit Analyte Input) sent by communications depend on each control model, and their scale readings are:

Type of measure	Scale reading	Value sent
Intensities	6 AAC	32767 counts
Voltages	132 (50Hz) or 144 (60HZ) V <sub>AC</sub>	32767 counts
Powers	± 2376 (50Hz) or 2592 (60HZ W / Var / Va	± 32767 counts
Power factor	± 1	± 32767 counts
Frequency	40 – 70 Hz (With metering card: 0 – 72 Hz)	0 - 32767 counts

The scaling of the magnitude **distance** is:

- 20 % --- 100 % scaling to 0 --- 32767 (16 bits)

So that:

Measurement	Value sent	Meaning
<-20 %	0	Invalid value (quiescent)
- 20 %	0	Invalid value (quiescent)
-20 ÷ 0 %	0	Invalid value (quiescent)
0 %	6553	Distance from 0 %
100 %	32767	Distance from 100 %
>100 %	0	Invalid value (quiescent)

## B.3.2 Communications

### B.3.2.a Communication with the equipment

The #FIT models can be fitted with an optional second rear port.

## B.4 Keypad and Alphanumeric Display

### B.4.1 DNP3.0 Protocol

From the main menu, the option **change settings** can be selected, as shown in Figure B.2. Then, the password is introduced via the keypad. If the password is correct, further options corresponding to this next level are displayed:

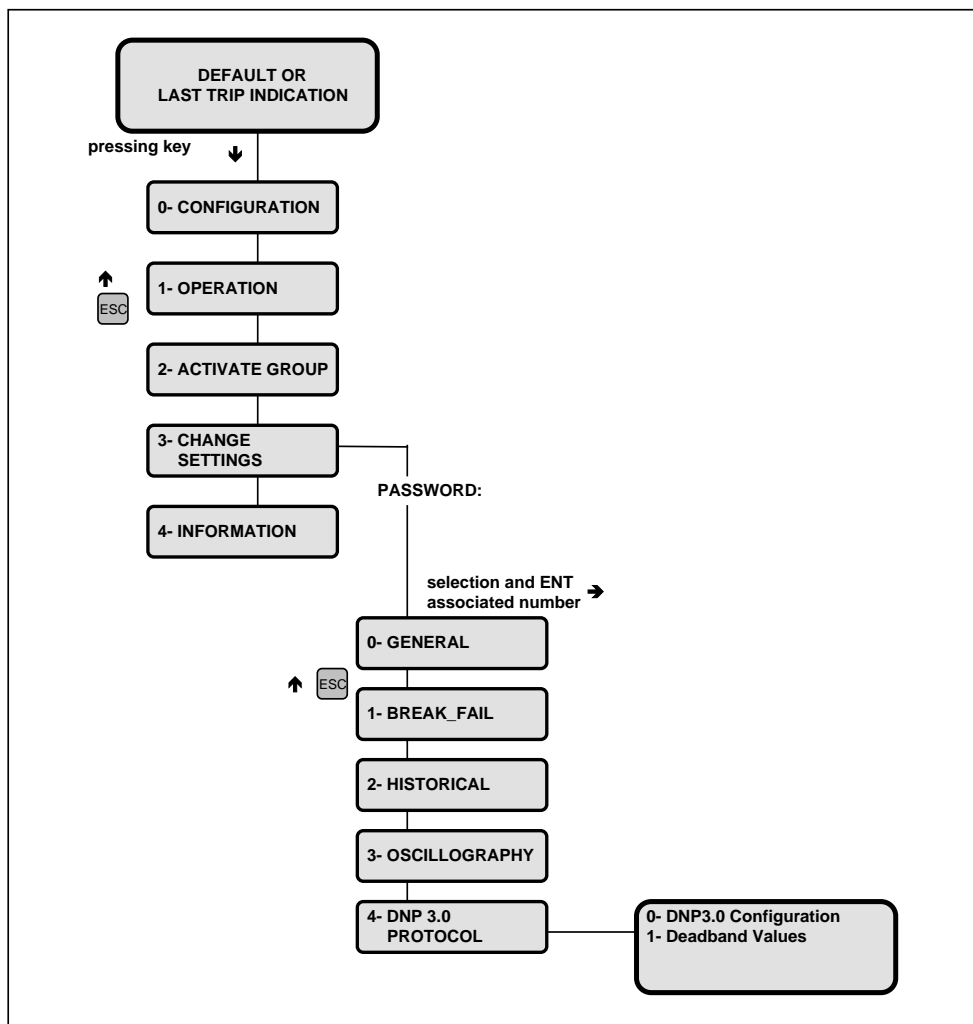

Figure B.2: DNP3.0 Protocol Operator Interface Menu.

- **DNP 3.0 Configuration**

Selecting first option **DNP 3.0 Configuration**, a new screen with the following options appears: **RTU Address**, **Reply Timeout N7**, **N7 Retry Counter**, **Enabl Unsol Report**, **MTU Address**, **Unsol Delay Report**, **Echo Ctrl Enable**, **N2 Retries**, **Pre-Transm. Time**, **Fixed Delay** and **Max. Random Delay**.

- **Metering Changes (Deadband Values)**

The second option, **Deadband Values**, presents the possibility to adjust independently the analogic meterin bands (according to equipment and model).

### **B.4.2 Information access**

The previous options are in the same position at information menu too. It's important to remember that at information menu the settings can be shown but they can't be modified.

ANNEX C

# **MODBUS RTU**

## **Protocol**



## Documentation specific to the models with the MODBUS RTU communication profile

### C.1 Preliminary Information

This document is intended as a reference on the implementation of the **MODBUS RTU** protocol in the **#FIT** protection relay.

This document describes the **MODBUS** map of addresses (inputs, outputs, metering registers and commands) and their equivalent in the **#FIT** relay.

The functions implemented are as follows:

ModBus Function	Description
01	Reading of Outputs (Read Coil Status)
02	Reading of Inputs (Read Input Status)
04	Reading of Metering Registers (Read Input Registers)
05	Commands (Force Single Coil)

Any other function non-included in the table above will be considered illegal and the exception code 01 (Illegal function) will be returned as a reply.

## C.2 Reading of Outputs (Read Coil Status)

### Map of Modbus addresses for the #FIT

The Output Modbus addresses assigned to the #FIT are as follows:

Address	Description
0200H (*)	Breaker Status
0207H	Aux-1 Status
0208H	Aux-2 Status
0209H	Aux-3 Status
020AH	Aux-4 Status
020BH	Aux-5 Status
020CH	Aux-6 Status
020DH	Aux-7 Status
020EH	Aux-1 Status (Virtual)
020FH	Aux-2 Status (Virtual)
0210H	Aux-3 Status (Virtual)
0211H	Aux-4 Status (Virtual)
0212H	Aux-5 Status (Virtual)
0213H	Aux-6 Status (Virtual)
0214H	Aux-7 Status (Virtual)
0215H	Active Group 1
0216H	Active Group 2
0217H	Active Group 3

Assigned addresses are fixed. The content of the addresses indicated with an (\*) is also fixed, the content of the other addresses being variable (it depends on the configuration selected by the end-user for each relay).

The remaining addresses of the range will be considered as illegal and the exception code 02 (Illegal Data Address) will be returned as a reply.

## C.3 Reading of inputs (Read Input Status)

### Map of Modbus addresses for the #FIT

The Input Modbus addresses assigned to the #FIT are as follows:

Address	Description
0000H	INPUT-1 Status
0001H	INPUT-2 Status
0002H	INPUT-3 Status
0003H	INPUT-4 Status
0004H	INPUT-5 Status
0005H	INPUT-6 Status
0006H	INPUT-7 Status
0007H	INPUT-8 Status
0008H	INPUT-9 Status
0009H	INPUT-10 Status
000AH	INPUT-11 Status
000BH	INPUT-12 Status
000CH	INPUT-13 Status
000DH	INPUT-14 Status
000EH	INPUT-15 Status
000FH	INPUT-16 Status

Assigned addresses are fixed, their content being variable (it depends on the configuration selected by the end-user for each relay).

The remaining addresses of the range will be considered as illegal and the exception code 02 (Illegal Data Address) will be returned as a reply.

## C.4 Reading of Metering Register (Read Input Registers)

### Map of Modbus addresses for the #FIT

The Modbus addresses for the Metering Input Registers assigned to the #FIT depend on the specific model.

Phase currents of each winding are always collected and if the relay has a ground connection, ground currents are also collected. If the relay comes with a thermal image unit, the value of the thermal percentage is also transmitted.

The magnitudes for one of the most complete case are as follows:

Address	Description
2000H	Phase A Current Metering
2001H	Phase A Voltage Metering
2002H	Phase B Current Metering
2003H	Phase B Voltage Metering
2004H	Phase C Current Metering
2005H	Phase C Voltage Metering
2006H	Phase A (x3) Active Power Metering
2007H	Phase A (x3) Reactive Power Metering
2008H	Phase A Power Factor

The rest of addresses of the range will be considered as illegal and the exception code 02 (Illegal Data Address) will be returned as a reply.

## C.5 Commands (Force Single Coil)

### Map of Modbus addresses for the #FIT

The range of Modbus addresses for commands in the #FIT is as follows:

Direction	Value	Function
0200H	0000H-OFF	Breaker Open
0200H	FF00H-ON	Breaker Close
0201H	0000H-OFF	Recloser Lockout
0201H	FF00H-ON	Recloser Lock

The rest of addresses of the range will be considered as illegal and the exception code 02 (Illegal Data Address) will be returned as a reply.

Any other value different from 00H or FHH will be considered as illegal and the exception code 03 (Illegal Data Value) will be returned as a reply.