

SCI

Synchronism Check Terminal Instructions Manual

License agreement for Software Embedded in Equipment

ZIV APLICACIONES Y TECNOLOGIA, S.L. End-User Software License Agreement

THE EQUIPMENT YOU HAVE PURCHASED INCLUDES EMBEDDED SOFTWARE PROGRAM(S). THE PROGRAM IS COPYRIGHTED AND IS BEING LICENSED TO YOU (NOT SOLD) FOR USE WITH THE EQUIPMENT.

THIS IS A LEGAL AGREEMENT BETWEEN US (AS “LICENSEE”) AND ZIV APLICACIONES Y TECNOLOGIA, S.L. (AS “LICENSOR”) FOR THE SOFTWARE PROGRAM INCLUDED WITH THE EQUIPMENT. PLEASE READ THE TERMS AND CONDITIONS OF THIS LICENSE AGREEMENT CAREFULLY BEFORE USING THE EQUIPMENT.

IF YOU INSTALL OR USE THE EQUIPMENT, YOU ARE ACCEPTING AND AGREEING TO THE TERMS OF THIS LICENSE AGREEMENT. IF YOU ARE NOT WILLING TO BE BOUND BY THE TERMS OF THIS LICENSE AGREEMENT, YOU SHOULD PROMPTLY RETURN THE EQUIPMENT UNUSED TO YOUR SELLER, AND YOU WILL RECEIVE A REFUND OF YOUR MONEY.

Terms and Conditions of License

1. **License Grant.** Licensor hereby grants to you, and your accept, a nonexclusive and non-transferable license to use the embedded programs and the accompanying documentation, if any (collectively referred to as the “Software”), only as authorized in this License Agreement.
2. **Restrictions.** You may not (a) use, copy, modify or transfer the Software except as expressly provided in this or another Agreement with Licensor, (b) reverse engineer, decompile or disassemble or separate the components of the Software, or (c) rent, sell or lease the Software or make the Software available to others to do any of the foregoing.
3. **No Assignment.** This License is intended for your exclusive use with the purchased equipment. You agree that you will not assign, sublicense, transfer, pledge, lease, rent or share your rights under this License Agreement.
4. **Licensor’s Rights.** You acknowledge and agree that the Software is the proprietary product of Licensor protected under U.S. copyright law and international treaties.. You further acknowledge and agree that all right, title and interest in and to the Software, including associated intellectual property rights, are and shall remain with Licensor. This License Agreement does not convey to you an ownership interest in or to the Software, but only a limited right of use revocable in accordance with the terms of this License Agreement.
5. **Confidentiality.** The Software is confidential and no details or information relating to the same shall be disclosed to any third party without the prior written consent of Licensor. For the purposes of this clause, sub-contract staff, employed or retained by the Licensee to perform computer systems development work, shall not be deemed to be third parties provided such staff are subject to the disclosure restrictions set forth above. In no event, except with a prior written authorization duly signed by an officer of Licensor, may you disclose any such confidential information, even for subcontracted jobs, to persons or entities that may be considered to be direct competitors of Licensor.

6. **Term.** The License Agreement is effective upon delivery of the equipment to you and shall continue until terminated. You may terminate this License Agreement at any time by returning the equipment to Licensor, or by destroying the equipment. Licensor may terminate this License Agreement upon your breach of any term hereof. Upon such termination by Licensor, you agree to return the equipment to Licensor.
7. **Warranty and Disclaimer.** Licensor warrants, for your benefit only, that the Software, when and as delivered to you, will conform to the specifications described in the instruction manuals for the equipment purchased, or any specifications agreed to in writing by Licensor with a particular customer. This warranty does not cover any minor errors or deviations from the specifications that do not affect the proper functioning of the equipment. **EXCEPT FOR THE WARRANTIES SET FORTH ABOVE, THE SOFTWARE IS LICENSED “AS IS”, AND LICENSOR DISCLAIMS ANY AND ALL OTHER WARRANTIES, WHETHER EXPRESS OR IMPLIED, INCLUDING, WITHOUT LIMITATION, ANY IMPLIED WARRANTIES OF MERCHANTABILITY OR FITNESS FOR A PARTICULAR PURPOSE.**
8. **Licensee’s Remedy.** Your sole and exclusive remedy for any breach of Licensor’s warranty shall be the repair or replacement, at Licensor’s sole option, of any Software that does not conform to stated specifications. Licensor shall not be responsible for any failure arising from inadequate or improper use of the Software.
9. **Limitation of Liability.** Licensor’s cumulative liability to you or any other party for any loss or damages resulting from any claims, demands, or actions arising out of or relating to this Agreement shall not exceed the purchase price paid to Licensor for the equipment. In no event shall Licensor be liable for any indirect, incidental, consequential, special, or exemplary damages or lost profits, even if licensor has been advised of the possibility of such damages.
10. **Trademark.** All ZIV trademarks (including ZIVERCOM, ZIVERLOG and ZIVERSYS) are common law trademarks of Licensor. No right, license or interest to such trademarks is granted hereunder, and you agree that no such right, license or interest shall be asserted by you with respect to such trademark.
11. **Licensee’s Indemnity.** You shall defend, indemnify and hold Licensor harmless against any loss or damage of any kind arising from a breach by you of this License Agreement, or any use or misuse of the Software by you or your employees, agents or representatives, and from any other of your conduct or from any claim or action by any of your customers in connection with the Software or this License Agreement.
12. **Governing Law.** This License Agreement shall be construed and governed in accordance with the internal laws of the State of Illinois, U.S.A.
13. **No Waiver.** The failure of either party to enforce any rights granted hereunder or to take action against the other party in the event of any breach hereunder shall not be deemed a waiver by that party as to subsequent enforcement of rights or subsequent actions in the event of future breaches.
14. **Entire Agreement.** This License Agreement is the entire agreement between you and Licensor with respect to the use of the software and supersedes all prior understandings or agreements between the parties. This License Agreement may be amended only by a writing signed by an officer of Licensor.

ZIV Aplicaciones y Tecnología, S.L.
Parque Tecnológico, 2089
48016 Zamudio (Vizcaya)
48080 Bilbao
Spain

Table of Contents



Chapter 1. Description		
1.1	Functions	1-2
1.2	Additional Functions	1-3
1.3	Model Selection	1-4
Chapter 2. Technical Data		
2.1	Power Supply Voltage	2-2
2.2	Power Supply Burden	2-2
2.3	Voltage Inputs	2-2
2.4	Measurement Accuracy	2-2
2.5	Repeatability	2-3
2.6	Digital Inputs	2-3
2.7	Synchronism Outputs and AUX-1	2-3
2.8	Auxiliary Outputs AUX-2 and AUX-3	2-3
2.9	Communications Link	2-4
Chapter 3. Standards and Type Tests		
3.1	Insulation	3-2
3.2	Electromagnetic Compatibility	3-2
3.3	Environmental Test	3-3
3.4	Power Supply	3-3
3.5	Mechanical Test	3-3
Chapter 4. Physical Architecture		
4.1	General	4-2
4.2	Dimensions	4-3
4.3	Connection Elements	4-4
4.3.1	Terminal Connectors	4-4
4.3.2	Removing Printed Circuit Boards (Non Self-Shorting)	4-4
4.3.3	Internal Wiring	4-4
Chapter 5. Settings		
5.1	Configuration Settings	5-2
5.2	General Settings	5-2
5.3	Protection Settings	5-2
5.4	Digital Inputs, Auxiliary Outputs and LED Targets	5-3
Chapter 6. Description of Operation		
6.1	Minimum Voltage Element (sides A and B)	6-2
6.2	Voltage Differential Element	6-2
6.3	Phase Angle Differential Element	6-2
6.4	Frequency Differential Element	6-2
6.5	Synchronism Element	6-2
6.6	Event Recording	6-3
6.7	Contact Inputs / Outputs & LED Targets	6-4
6.7.1	Status Contact Inputs	6-4
6.7.2	Auxiliary Contact Output	6-5
6.7.3	LED Targets	6-6



6.8	Communications	6-7
6.8.1	Communications Settings	6-7
6.8.2	Communications Types	6-7
6.8.3	Communicating with the Unit	6-7
6.9	Application.....	6-8
Chapter 7. Alphanumeric Keypad and Display		
7.1	Alphanumeric Display and Keypad	7-2
7.2	Keys, Functions and Operation Modes.....	7-3
7.3	Screen Sequence Using a Single Key.....	7-4
7.4	Screen Sequence Using the Complete Keypad	7-6
Chapter 8. Receiving Tests		
8.1	General	8-2
8.1.1	Accuracy	8-2
8.2	Preliminary Inspection.....	8-3
8.3	Insulation Test.....	8-3
8.4	Voltage Measuring Test.....	8-4
8.5	Frequency Measuring Test	8-4
8.6	Phase Angle Measuring Test.....	8-4
8.7	Synchronism Element Test.....	8-5
8.8	Status Contact Inputs and LED Targets Test	8-6
8.9	Communications Test	8-7
8.10	Installation	8-7
8.10.1	Location.....	8-7
8.10.2	Connection.....	8-7
Annex A. Schemes and Drawings		
Annex B. List of Illustrations and Tables		
B.1	List of Illustrations	B-2
B.2	List of Tables.....	B-2
Annex C. Warranty		

1. Description



1.1	Functions	1-2
1.2	Additional Functions.....	1-3
1.3	Model Selection	1-4



SCI protection relay is designed for synchronism checking between two electrical networks using the state-of-the-art digital technology.

The terminals are also equipped with two minimum voltage units, capable of disabling the synchronism measuring element unit, in specific circumstances.

The design of the **SCI** terminal provides for easy installation with the ability to be integrated into a system with other protection units (**CPI**, **MXI**, **FGI**, etc.).

1.1 Functions

- **Minimum Voltage Element (2x27)**

Two minimum voltage elements are included on each **SCI** terminal. These elements enable the closing operation when absence of voltage is detected on either side of the circuit breaker. They are also capable of inhibiting the synchronism measuring element if voltage is less than a user defined setting value.

It is possible to enable or disable the minimum voltage units through user settings. An option to determine (independently for each side of the circuit breaker) minimum voltage for synchronism checking is also available.

- **Synchronism Check (25)**

Synchronism is checked by measuring the difference between voltages, frequency, and phase angle magnitudes at both sides of the breaker. The difference values are independently adjustable in the **SCI** terminal.



1.2 Additional Functions

- **LED Targets**

There are eight LED targets, seven of which are configurable while the eighth indicates "Ready". The list of available signals that can be assigned to the LED targets is provided in Chapter 6, while Schemes and Drawings gives an example of their configuration (see Annex).

- **Status Contact Inputs**

The unit has two configurable status contact inputs. Chapter 6 indicates the inputs available for the unit.

- **Auxiliary Contact Outputs**

There are three configurable auxiliary contact outputs (two of which can be configured through communications). Auxiliary output AUX-3, which corresponds to "Terminal Unit in Service" (powered up, self-test OK), is not programmable.

A list of available outputs is defined in Chapter 6. The default configurations are described in Schemes and Drawings (at the end of this instructions manual). Contact Outputs are pairs of switched contacts NO or NC. Contact Output AUX-1 may be configured as NO and/or NC by means of internal jumpers.

- **Local Information (display)**

The units have an alphanumeric display for viewing information about operations and metering:

- **Events:**

- Last relay operation (activated element and date)
- Status contact inputs status
- Auxiliary contact outputs status

- **Measuring:**

- Side A Voltage
- Side B Voltage
- Phase angle between side A and side B signals
- Frequency difference between side A and side B signals

- **Self-Test Program**

The unit has a self-test program that verifies the proper operation of all the components of the system.



1.3 Model Selection

	SCI		0	B				0	0	0			
1	2	3	4	5	6	7							
1	Selection												
	3 Vertical Format			8 Horizontal Format									
2	Functions												
	A 25 + (2x27)												
3	Power Supply												
	1 24 - 48 Vdc (*)			Digital Inputs									
	2 110 - 125 Vdc (*)			24 - 48 Vdc									
	3 220 - 250 Vdc (*)			24 - 125 Vdc									
				48 - 250 Vdc									
4	Voltage / Frequency / Language												
	1 110 and 110/3V, 50Hz, Spanish			D 120 and 120/3V, 60Hz, Spanish									
	3 120 and 120/3V, 60Hz, English			F 120 and 120/3V, 60Hz, Portuguese									
	B 110 and 110/3V, 50Hz, English												
5	Communications												
	1 RS232 + RS232			3 RS232 + Glass F.O. (conn. SMA)									
	2 RS232 + Plastic F.O. (1 mm.)			4 RS232 + Glass F.O. (conn. ST)									
6	Type of enclosure												
	D 6U x 1/7 19 rack"			V 19" rack, 6U									
7	Communications Protocol												
	A Protec. PROCOME + without Control												

* ±20

- **Functions**

25	Synchronism Check.
27	Minimum Voltage.

2. Technical Data



2.1	Power Supply Voltage	2-2
2.2	Power Supply Burden	2-2
2.3	Voltage Inputs	2-2
2.4	Measurement Accuracy	2-2
2.5	Repeatability	2-3
2.6	Digital Inputs	2-3
2.7	Synchronism Outputs and AUX-1	2-3
2.8	Auxiliary Contact Outputs AUX-2 and AUX-3	2-3
2.9	Communications Link	2-4



2.1 Power Supply Voltage

Selectable range depending on model:

24 - 48Vdc ($\pm 20\%$)
110 -125Vdc ($\pm 20\%$)
220 - 250Vdc ($\pm 20\%$)

Note: In case of power supply failure, a maximum interruption of 100 ms is allowed for 110 Vdc input.

2.2 Power Supply Burden

Quiescent	7 W
Maximum	11 W

2.3 Voltage Inputs

Rated value	V_n = 110 V (50 Hz) V_n = 120 V (60 Hz)
Thermal withstand capability	2V_n (continuously)
Voltage circuit burden	V_n = 110V < 0.5VA

2.4 Measurement Accuracy

Measured voltages	
Internal measure accuracy	< 5 %
Display measure accuracy	< 5 % $\pm 1V$
Measured frequencies	
Internal frequency accuracy	< 0.005 Hz
Display frequency accuracy	< 0.01 Hz
Measuring times	
Characteristic	<5 % or <25ms (sync by U) <5 % or <100ms (sync by f or ϕ) (the greater for both cases)
Phase angle measurement accuracy	
Characteristic	< 3 °



2.5 Repeatability

Operating time	2 % or 25 ms (the greater)
----------------	-----------------------------------

2.6 Digital Inputs

Two electrically separate, user-programmable inputs

Digital Input Voltage Range	24 - 125 Vdc ($\pm 20\%$)
(selectable range depending on the model)	48 - 250 Vdc ($\pm 20\%$)
Current Drain	<5 mA

2.7 Synchronism Outputs and AUX-1

Two trip contacts internally configurable as NO or NC
AUX-1 switched contact internally configurable as NO and/or NC

I DC maximum limit (with resistive load)	5 A for 30 s
I DC continuous service (with resistive load)	8 A
Connection Capacity	2500 W
Breaking capability (with resistive load)	150 W - max. 8 A - (48 Vdc) 55 W (80 Vdc - 250 Vdc)
	1250 VA
Switching voltage	250 Vdc
Momentary close time trip contacts remain closed	40 ms

2.8 Auxiliary Contact Outputs AUX-2 and AUX-3

Electrically separate auxiliary switched contact outputs NO or NC

I DC maximum limit (with resistive load)	5 A for 30 s
I DC continuous service (with resistive load)	3 A
Connection Capacity	2000 W
Breaking capability (with resistive load)	75 W - max. 3 A - (48 Vdc) 40 W (80 Vdc - 250 Vdc)
	1000 VA
Switching voltage	250 Vdc



2.9 Communications Link

Remote Communications	Glass F.O.; Plastic F.O.; RS232
Local Communications	RS232

Glass Fiber Optic	
Type	Multimode
Wavelength	820 nm
Connector	ST
Transmitter Minimum Power	
50/125 fiber	- 20 dBm
62.5/125 fiber	- 17 dBm
100/140 fiber	- 7 dBm
Receiver Sensitivity	- 25.4 dBm

Plastic Fiber Optic (1 mm)	
Wavelength	660 nm
Transmitter Minimum Power	- 16 dBm
Receiver Sensitivity	- 39 dBm

RS232C Port Signals	
Connector dB-9 (9 pin) signals used	Pin 5 - GND
	Pin 2 - RXD
	Pin 3 - TXD

3. Standards and Type Tests



3.1	Insulation.....	3-2
3.2	Electromagnetic Compatibility	3-2
3.3	Environmental Test.....	3-3
3.4	Power Supply.....	3-3
3.5	Mechanical Test.....	3-3



3.1 Insulation

Insulation Test (Dielectric Strength)	<i>IEC-60255-5</i>
Between all circuit terminals and ground:	2 kV, 50 Hz , for 1 minute
Between all circuit terminals:	2 kV, 50 Hz , for 1 minute
Voltage Impulse Test	<i>IEC-60255-5 (UNE 21-136-83/5)</i>
	5 kV; 1.2/50 μs; 0.5 J

3.2 Electromagnetic Compatibility

1 MHz Burst Test	<i>IEC-60255-22-1 Class III</i> <i>(UNE 21-136-92/22-1)</i>
Common Mode:	2.5 kV
Differential Mode:	1.0 kV
Fast Transient Disturbance Test	<i>IEC-60255-22-4 Class IV</i> <i>(UNE 21-136-92/22-4)</i> <i>(IEC-61000-4-4)</i>
	4 kV \pm10 %
Radiated Electromagnetic Field Disturbance	<i>IEC-61000-4-3</i>
Amplitude modulated (<i>EN 50140</i>)	10 V/m
Pulse modulated (<i>EN 50204</i>)	10 V/m
Conducted Electromagnetic Field Disturbance	<i>EN 50141</i>
Amplitude modulated	10 V
Electrostatic Discharge	<i>IEC-60255-22-2 Class III</i> <i>(UNE 21-136-92/22-2) (IEC 1000-4-2)</i>
	\pm8 kV \pm10 %

Radio Frequency Emissivity	<i>EN 55011 (IEC-61000-4-6)</i>
-----------------------------------	---------------------------------



3.3 Environmental Test

Temperature	<i>IEC-60255-6</i>
Operating Range:	From -10 °C to +55 °C
Storage Range:	From -25 °C to +70 °C
Humidity:	95 % (non-condensing)

3.4 Power Supply

Power Supply Ripple	<i>IEC-60255-11 / UNE 21-136-83 (11)</i> < 20 %
----------------------------	--

3.5 Mechanical Test

Vibration Test (sinusoidal)	<i>IEC-60255-21-1 Class I</i>
Mechanical Shock and Bump Test	<i>IEC-60255-21-2 Class I</i>

The models comply with the Directive 89/336/EEC of electromagnetic compatibility



4. Physical Architecture



4.1	General	4-2
4.2	Dimensions	4-3
4.3	Connection Elements.....	4-4
4.3.1	Terminal Connectors.....	4-4
4.3.2	Removing Printed Circuit Boards (Non Self-Shorting).....	4-4
4.3.3	Internal Wiring.....	4-4



4.1 General

SCI protection terminals consist of a circuit board with the following functions:

Power Supply

- Central Processing Unit
- Analog Inputs
- Contact Inputs and Outputs

Depending on the terminal settings, all the contact inputs / outputs may be used or remain as spare signals.

The external appearance of the unit seen from the front is represented in figures 4.1 and 4.2. Dimensions are specified at the end of this manual.

Keypad, alphanumeric display and local communications port are located on the front panel.

The rear panel contains terminal connectors as shown in figures 4.3 (8SCI models) and 4.4 (3SCI models). Of the two connectors indicated, one corresponds power supply input and contact inputs and outputs (20 terminal connectors all together) and the other to the transformer secondary analog inputs (5 terminal connectors, the first four used for the two analog inputs and the fifth is grounding filter channels).

The relay is provided with communications connectors both in the front and the rear.

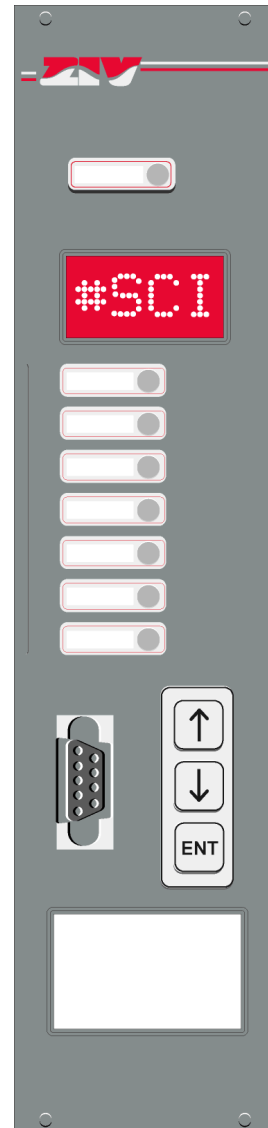

Figure 4.1: 3SCI Front View.

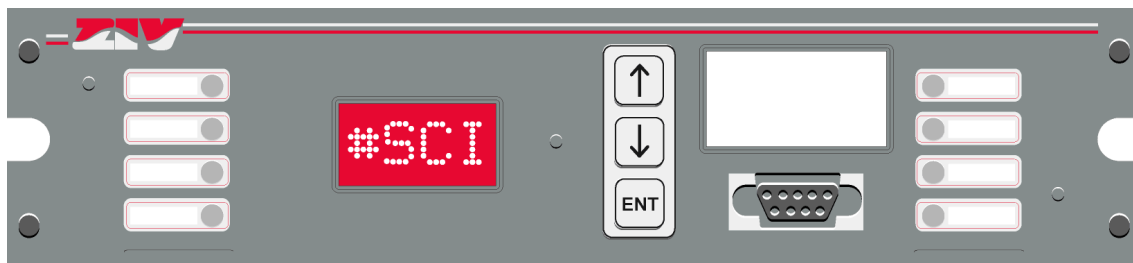

Figure 4.2: 8SCI Front View.

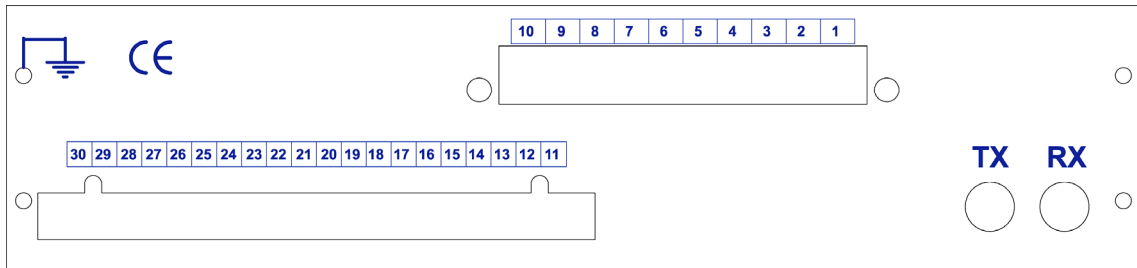

Figure 4.3: 8SCI Rear View.

4.2 Dimensions

SCI protection terminal unit case dimensions are 1/7 of a 19" rack wide, and 6 standard rack units high (10½"). **3SCI** terminals are vertical mount units, and **8SCI** terminals are horizontal mount units. The equipment is intended to be installed either semi-flush mounted on panels or inside a 19" rack. The **SCI** comes equipped with a transparent cover, which can be sealed for security purposes. The enclosure colour is graphite.

Note: 8SCI models are designed to be mounted on 1 Rack wide x 2U high adapter element. Dimension drawings for this adapter are given at the end of this instructions manual.

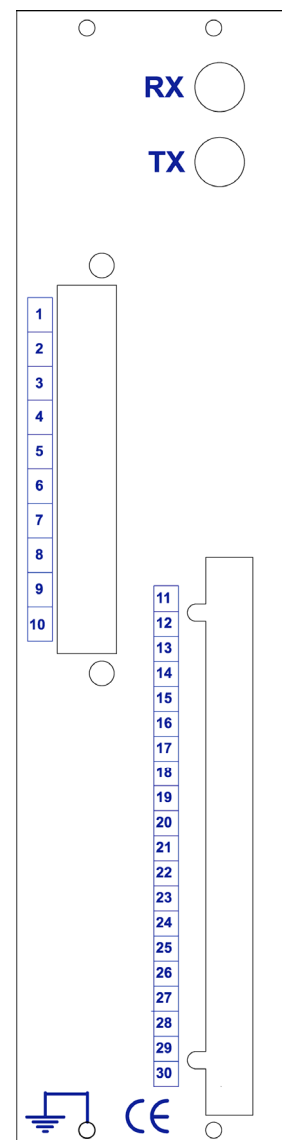

Figure 4.4: 3SCI Rear View.



4.3 Connection Elements

4.3.1 Terminal Connectors

Terminal connectors are permanently attached to the rear edge of the printed circuit board to facilitate external wiring and are arranged in rows or columns depending on the model.

- One row or column of 5 terminal connectors for transformer secondary inputs.
- One row or column of 20 terminal connectors for power supply input and contact inputs and outputs.

Voltage analog input terminals accept up to #11 AWG wire. The remaining circuit terminals permit wire up to #14 AWG. Communications connectors are provided on both front and rear equipment panels.

4.3.2 Removing Printed Circuit Boards (Non Self-Shorting)

The equipment has been designed to enable removal of the printed circuit board. The printed circuit board is attached to the case using self-tapping screws. These screws must be removed before the board is withdrawn. It is also necessary to remove the screws on the terminal connectors. Whenever this operation is performed, the **SCI** terminal should be placed in the "Not in Service" mode, and turned off.

4.3.3 Internal Wiring

The equipment uses traditional printed circuit board connections and internal *buses* to minimize internal wiring.

5. Settings



5.1	Configuration Settings.....	5-2
5.2	General Settings	5-2
5.3	Protection Elements Settings.....	5-2
5.4	Digital Inputs, Auxiliary Outputs and LED Targets	5-3



5.1 Configuration Settings

Communications (Local and Remote Port Configuration)	
Setting	Range
Terminal Address	0 to 254
Baud Rate	300 to 19200 Bauds
Stop Bits	1 or 2
Parity	1 (Even parity) / 0 (No parity)

Date and Time
Adjustable through communications

Language	
Setting	Range
Language	Spanish English Portuguese

5.2 General Settings

General Settings		
Setting	Range	Step
PT Ratio	1-4000	1
Events masking (only through communications)	All the events	

5.3 Protection Elements Settings

Protection Settings		
Setting	Range	Step
ΔU element pickup enable	YES / NO	
ΔU element pickup (between A-B)		
Communications	2 - 30 %	1
HMI	0.02 - 0.30 % ₁	0.01
$\Delta \Phi$ element pickup enable	YES / NO	
$\Delta \Phi$ element pickup (between A-B)	5 - 50°	1°
Δf element pickup enable	YES / NO	
Δf frequency difference (between A-B)	0.05 - 2.00 Hz	0.01 Hz
UA < undervoltage element pickup enable	YES / NO	
UA < undervoltage element pickup (side A)	20 - 100 V	1 V
UB < undervoltage element pickup enable	YES / NO	
UB < undervoltage element pickup (side B)	20 - 100 V	1 V
Close permit check time delay	0 - 60 s	0.1 s

Note: To disable protection elements through the keypad, select the value 000. To disable protection elements through communications, cancel the "Pickup Enable" option. In case that a minimum voltage element is disabled, the voltage difference element will be disabled automatically.



5.4 Digital Inputs, Auxiliary Outputs and LED Targets

Digital Inputs, Auxiliary Outputs and LED Targets Configuration

Users can easily program different input, output and LED target configurations via the local RS232 communications port, using the **ZIVercom**® software.

The auxiliary contact outputs and AUX-1 are configurable as N.O or N.C contacts using internal jumpers located as described in figure 5.1

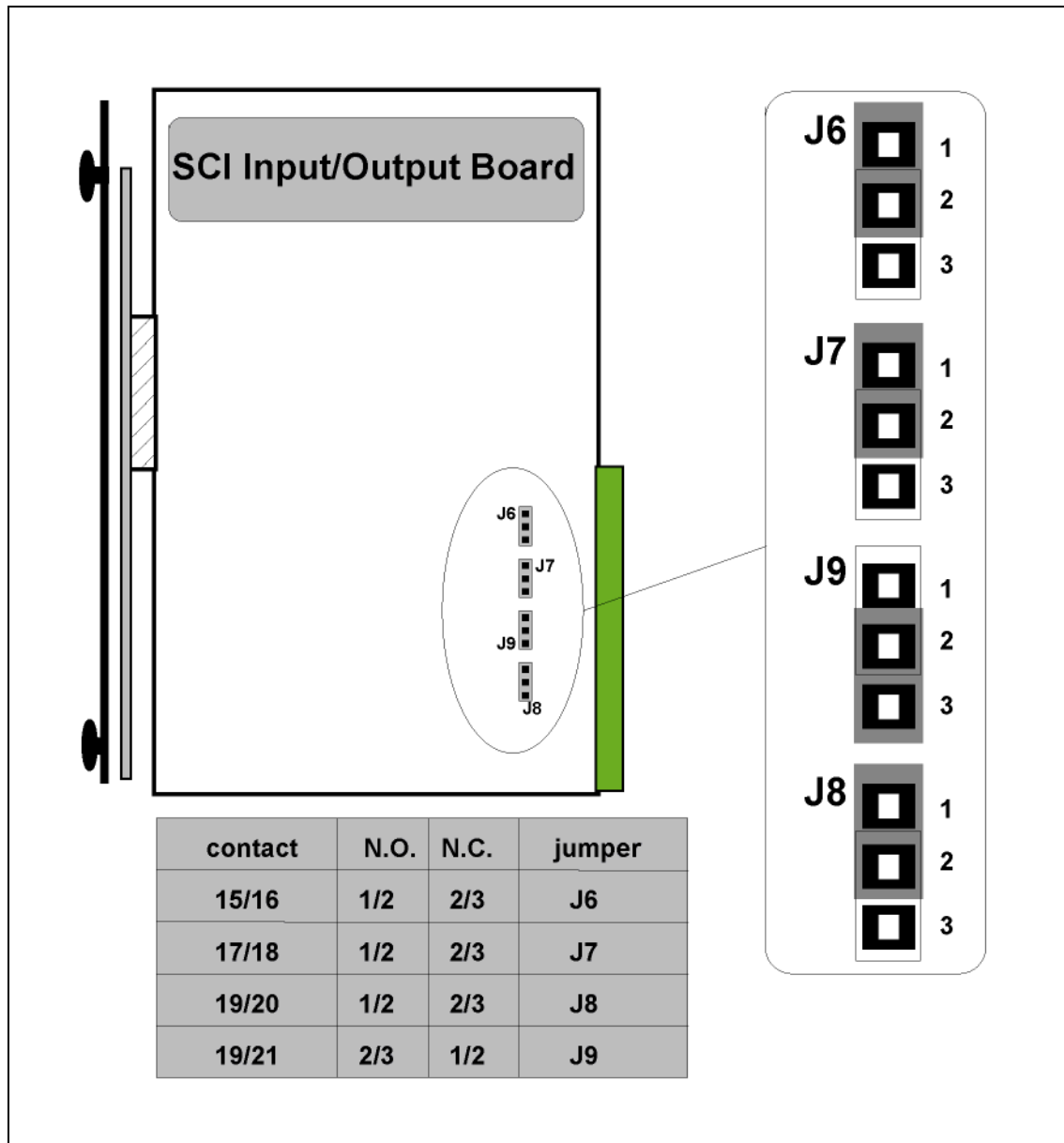

Figure 5.1: Internal Jumpers.



6. Description of Operation



6.1	Minimum Voltage Element (sides A and B)	6-2
6.2	Voltage Differential Element	6-2
6.3	Phase Angle Differential Element	6-2
6.4	Frequency Differential Element	6-2
6.5	Synchronism Element	6-2
6.6	Event Recording	6-3
6.7	Contact Inputs, Outputs & LED Targets	6-4
6.7.1	Status Contact Inputs	6-4
6.7.2	Auxiliary Contact Output	6-5
6.7.3	LED Targets	6-6
6.8	Communications	6-7
6.8.1	Communications Settings	6-7
6.8.2	Communications Types	6-7
6.8.3	Communicating with the Unit	6-7
6.9	Application	6-8



6.1 Minimum Voltage Element (sides A and B)

Minimum voltage element pickup occurs when the measured voltage value is greater than 105% of the pickup setting value. Reset takes place when measured value is less than or equal to 100% of the pickup setting. This element does not pickup for minimum voltage conditions.

The equipment is designed to detect zero voltage level, even when the minimum voltage element is disabled (setting 000), in order to avoid frequency element activation.

6.2 Voltage Differential Element

Voltage differential element pickup takes place when the voltage difference between side A and side B is less than or equal to the pickup setting value. The reference value is the side with least voltage (if $V_A < V_B$, $\Delta U = (V_B - V_A)/V_A$). Reset takes place when measured value exceeds +5% of the pickup setting.

6.3 Phase Angle Differential Element

Phase angle differential element pickup occurs when the phase angle difference between side A and side B is less than or equal to the pickup setting value. Reset takes place when measured value exceeds by $+0.5^\circ$ the pickup setting. This element needs at least three cycles for correct metering.

6.4 Frequency Differential Element

Frequency differential element pickup occurs when the frequency difference between sides A and B signals is less than the pickup setting value (100% of the setting). Reset takes place when measured value exceeds the pickup setting in 0.005 Hz. This element needs at least three cycles for correct metering.

6.5 Synchronism Element

Synchronism condition or close permit contact output will close provided that every condition is satisfied as defined by the settings of the protection elements - voltage, phase angle and frequency - during the adjusted time in the close permit timer.

Contact outputs 15-16 and 17-18 are linked to the settings of the protection elements, therefore, to become active it is necessary that every protection element enabled has picked up.

In case that more than one synchronism condition is needed, auxiliary contact outputs must be used. A series of auxiliary contact output configurations with different synchronism criteria are defined in the application section.



6.6 Event Recording

Protection functions that are monitored by the sequence of events portion of the terminal unit are listed in Table 6.1.

Function	Description	Byte	Bit
Initialization [1]	Power Up	1	4
	Change of Settings Initialization	1	5
Synchronism Protection [44]	Enable Check of Side A Minimum Voltage Element Close Permit	1	1
	Enable Check of Side B Minimum Voltage Element Close Permit	1	2
	Close Enable Check Element Pickup	1	3
	Close Enable Check Element Trip Output Active	1	4
	Voltage Differential Element Close Permit	1	5
	Phase Angle Differential Element Close Permit	1	6
	Frequency Differential Element Close Permit	1	7

- **Event Organization**

Event date and time is stored in each event register. The event record capacity is forty (40) events. When the record is full, a new event displaces the oldest event.

- **Event Consulting**

The **ZIVcom**[®] communications and remote management software program is used for reading event information.

Note: Events will record, only if circuit breaker closes.

- **Event Masking**

It is possible to mask unneeded events or those events without importance for the study of protection behaviour. Event masking can be done only through communications, and is available in the general settings menu.



6.7 Contact Inputs, Outputs & LED Targets

SCI terminal units are provided with programmable inputs and outputs enabling user configuration of flexible logic designs. The following paragraphs contain a description of the programming structure to configure protection inputs, outputs and signalling. Factory default settings may be modified using the **ZIVercom**[®] software program.

6.7.1 Status Contact Inputs

The terminal unit metering elements, and logic functions use the Logic Input Signals listed in Table 6.2 below. Any of these Logic Input Signals can be assigned to one of the two Status Contact Inputs of the terminal unit. The closure of a contact will thereby activate those Logic Input Signals assigned to it. Several different Logic Input Signals can be assigned to one Status Contact Input, but a given Logic Input Signal can only be assigned to one Status Contact Input.

Number	Name	Description	Function
1	IC	Open Breaker Status	Control of the Status of the Breaker.
2			
2			
3			
4			
5			
6			
7	BAPC	Block Close Permit Check Element Pickup	Close Permit Check Blocks.
8	BASPC	Block Close Permit Check Element Trip Output Activation	

BAPC and **BASPC** inputs must be active before the signal to be blocked is generated.

Schemes and Drawings, at the end of this instructions manual, details the status contact input/logic input signal assignments set at the factory. Users can easily program different input settings using the local RS232 communications port and the **ZIVercom**[®] software or can request this be completed by the manufacturer.



6.7.2 Auxiliary Contact Output

Terminal unit metering elements and logic functions generate a series of Logic Output Signals during terminal unit operation. Each of these signals has either a “True” or “False” value and this status can be used as an input to either of the combinational logic gates shown in Figure 6.1.

Two logic gates are available in each cell. Each gate accepts up to 8 Logic Output Signals. The output of these two gates is operated by a selectable second gate. The desired final “AND” or “OR” output from the logic cell can then be connected to any one of the two programmable Auxiliary Contact Outputs (AUX-1 and AUX-2) available in the terminal unit. Auxiliary Contact Output (AUX-3) which corresponds to Relay in Service is not programmable.

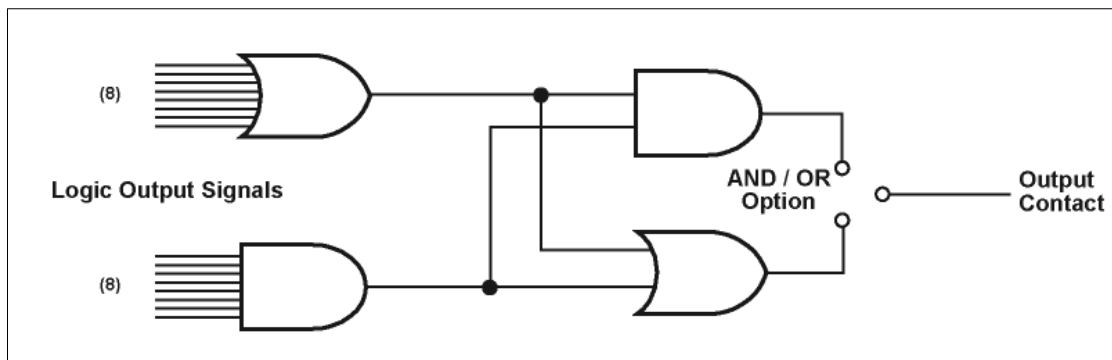

Figure 6.1: Auxiliary Contact Output Logic Cell Block Diagram.

The available Logic Output Signals are described in table 6.3.

Table 6-3: Auxiliary Contact Output			
Number	Name	Description	
1	SUBT_A	Side A Minimum Voltage Element Close Permit	Minimum Voltage Element Close Permit Activations.
2	SUBT_B	Side B Minimum Voltage Element Close Permit	
3	APC	Close Permit Check Element Pickup	The same as the Status Contact Inputs.
4	ASPC	Close Permit Check Element Trip Output Active	
5	HPT	Voltage Differential Element Close Permit	Voltage, Phase angle and Frequency Element Close Permit Activations.
6	HPA	Phase Angle Differential Element Close Permit	
7	HPF	Frequency Differential Element Close Permit	
8			
9			
10			
11	ED1	Status Contact Input DI-1 Active	Digital Inputs Activation.
12	ED2	Status Contact Input DI-2 Active	

Logic Output Signals **SUBT_A** and **SUBT_B** will be always active when the corresponding voltage is over the adjusted value, or when the minimum voltage element pickup is disabled.



6.7.3 LED Targets

SCI terminal units are provided with eight optical indicators (**LEDs**) located on the front panel. Seven of the **LEDs** are user definable. The eighth **LED** is always assigned to indicate the terminal unit is "Ready" (powered up, self-test OK). The logic cell structure, shown in the block diagram of Figure 6.2, permits the user to create combinational logic equations for the **LED Target Outputs**. To configure **LED Target Outputs**, Logic Output Signals are assigned to a **LED Target Output**. The available Logic Output Signals are shown in Table 6.3.

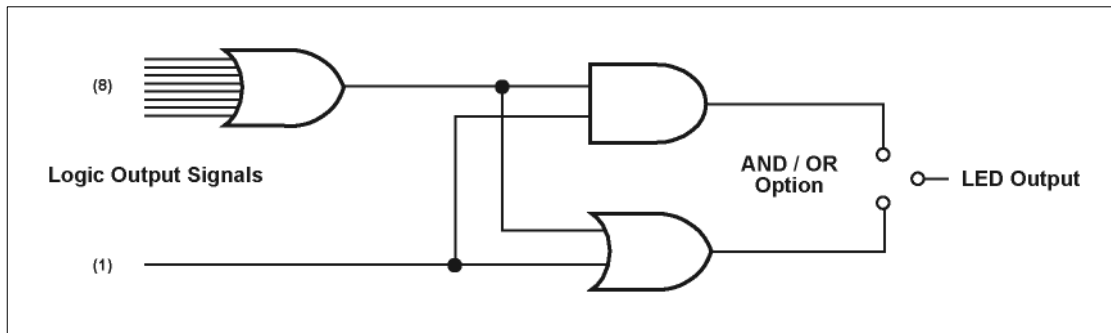

Figure 6.2: LED Target Output Logic Cell Block Diagram.

Each **LED** can be defined as latched or unlatched. If an **LED** is latched it will remain illuminated until reset, even after a condition has disappeared. **LED** resetting is accomplished via the keypad (see Chapter 7 Alphanumeric Keypad and Display).

The latching function resides in the volatile memory section of the microprocessor. A power supply loss will cause any latched **LED** to reset.

Each **LED** is pre-programmed with default logic. This logic can be modified by using the local RS232 communications port and the **ZIVercom**® software or can be completed by the manufacturer before delivery at customer request.

Each **LED** can be assigned to any Logic Output Signal contained in Table 6.3 and Table 6.4:

Table 6-4: LEDs		
Number	Name	Description
13	DISP	Trip Output 1 Active (Synchronism)
14	AAUX1	Status Contact Output AUX1 Active
15	AAUX2	Status Contact Output AUX2 Active
16	AAUX3	Status Contact Output AUX3 Active



6.8 Communications

6.8.1 Communications Settings

Communications settings are listed in Chapter 5 (Settings) and include the unit number, baud rate, stop bits, and parity.

6.8.2 Communications Types

SCI terminals have two communications ports: an RS232C fixed port on the front panel, and another optional port at the rear, which can be glass fiber optics, 1-mm plastic fiber optics and RS232C. Technical data relative to these ports is given in Chapter 2 (Technical Data).

6.8.3 Communicating with the Unit

Communications via these ports are achieved using the **ZIVercom**[®] communications software, which enables dialog with the **SCI** family of units and other equipment, either **locally** (via PC connected to the front port) or **remotely** (via the rear serial port), to cover any programming, setting, record or report needs, etc.

The communications software which covers the models in question, **ZIVercom**[®], is a user-friendly, Windows[™] based software tool that is password-protected to provide access only to authorized personnel. The software allows easy navigation of and access to available settings and actions through a series of intuitive menus and graphical user interfaces.

The following information on the status of the unit that can be accessed in both local and remote modes:

- Metering display
- Settings
- Inputs
- Outputs / LEDs
- Event Records



6.9 Application

The **SCI** has been designed to check synchronism conditions for two electrical systems before allowing the circuit breaker to close. Therefore, the primary function of **SCI** units is to allow or avoid the closing of the circuit breaker when the close order has been sent by other device. The **SCI** operates when the two circuits to be connected are within the desired limits of voltage, phase angle, and frequency.

SCI units are devices to measure single phase voltages on both sides of the breaker. An included options is to restrict operation for a given voltage at both sides of the breaker or for zero voltage, depending the application. Two minimum voltage elements are included for that purpose.

Figure 6.3 shows an application example for the **SCI** relay. Manual switch contact CS allows operation of the element 25, which allows circuit breaker to close when synchronism conditions are present. Contact 15 - 16 represent the metering elements used to allow circuit breaker to close when measured values are within range of the settings. Contact 19 - 20 represent auxiliary output AUX1. AUX1 may be configured as described in Figure 6.3.

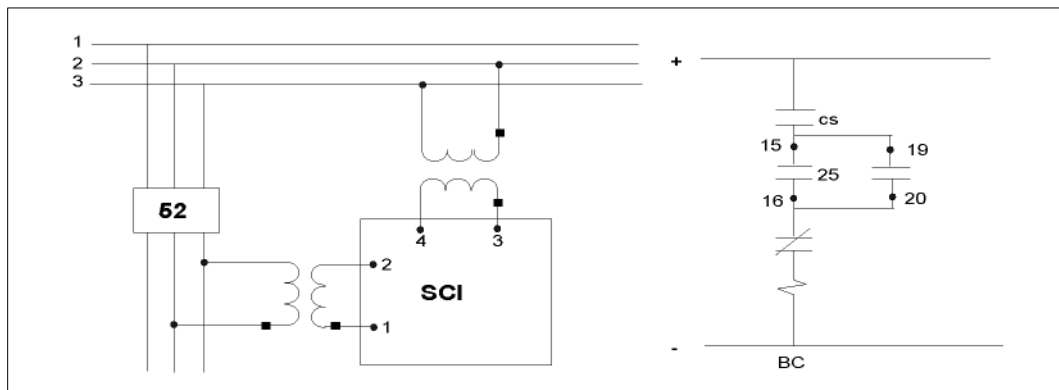

Figure 6.3: Schematic for a Synchronism-Check Relay.

Figure 6.4 shows other **SCI** application example. In this case the **SCI** is used to monitor manual CB closing or reclosing after fault.

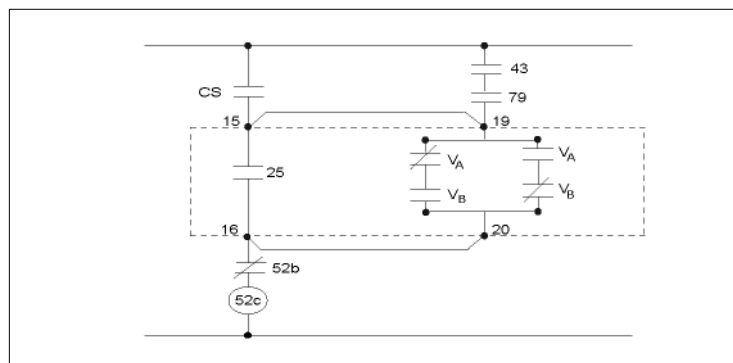

Figure 6.4: Synchronism Check Example.



Following figure represents some examples of auxiliary outputs typical configurations according to different types of synchronism.

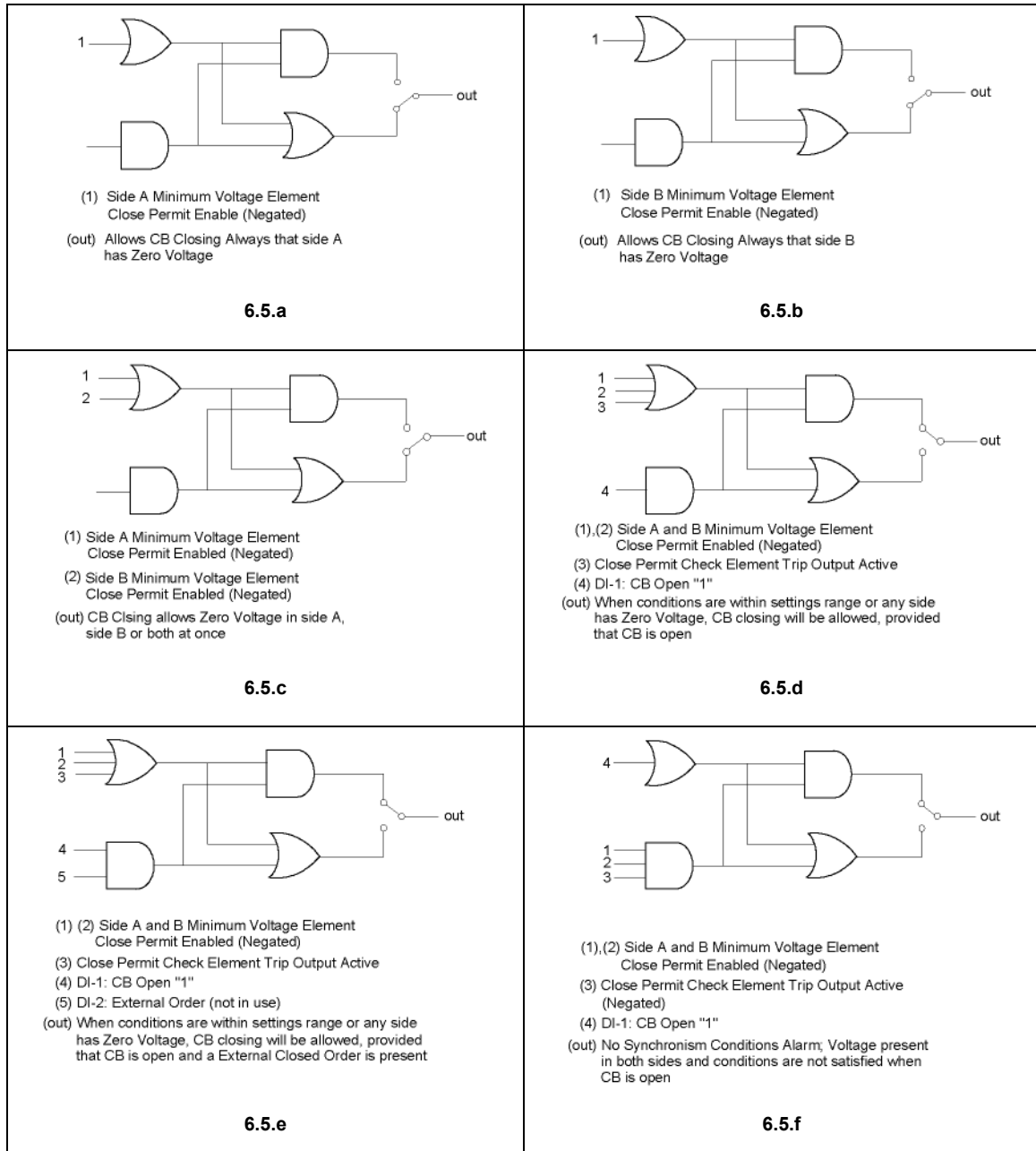

Figure 6.5: Auxiliary Output Configuration Examples.



There are two factors to take into account when adjusting the settings for phase angle difference, frequency, and time delay: (1) the operation time for the unit is approximately 100 ms when either the $\Delta\phi$ or Δf elements are used, and (2) circuit breaker operation time. During this operation time, if the frequency is different in each side, the phase angle between voltages will vary.

For example, if CB closing is allowed with $\Delta f < 0.1\text{Hz}$, the phase angle difference generated in 140ms is 5.04° ($0.1\text{Hz} \Rightarrow 10.000\text{ms}$ for 360°). Therefore, minimum $\Delta\phi$ must be 7° . According to these settings ($\Delta f < 0.1\text{Hz}$ and $\Delta\phi < 7^\circ$), time delay should not exceed 100 ms (having 100ms relay operation time + 100ms time delay + 40ms CB operation time). With this time the phase angle at closing would be about 1.64° ($8.64^\circ - 7^\circ$). For time delay=0 the phase angle at closing would be -1.96° ($5.04^\circ - 7^\circ$). The option with the time delay would be safer since synchronism conditions have been checked for a longer time.

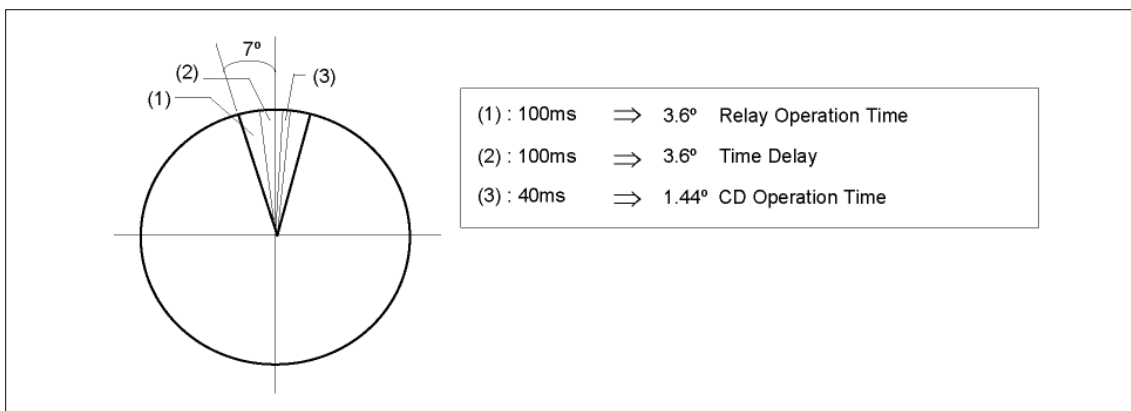

Figure 6.6: Example of Phase Angle Difference Setting $\Delta\phi$, Δf , and Time Delay.

7. Alphanumeric Keypad and Display



7.1	Alphanumeric Display and Keypad.....	7-2
7.2	Keys, Functions and Operation Modes.....	7-3
7.3	Screen Sequence Using a Single Key.....	7-4
7.4	Screen Sequence Using the Complete Keypad	7-6



7.1 Alphanumeric Display and Keypad

The liquid crystal alphanumeric display has 1 row, 4-column matrix, with each position in the matrix containing 7x5 pixels. The display provides information on terminal unit alarms, settings, metering, status, etc. The default display shows the relay model as described in figure 7.1.



Figure 7.1: Alphanumeric Display.

The **SCI** keypad consists of 3 keys as shown in figure 7.2. If the relay has its cover installed, only the down arrow ↓ key is accessible.

From the default screen, there are two ways of operating with the keyboard: using a single key or using the three keys.

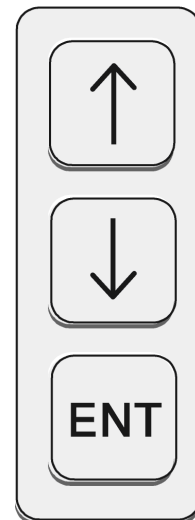

Figure 7.2: Keypad.



7.2 Keys, Functions and Operation Modes

- **Option Selection**

The two arrow keys (↑↓) provide access to any of the options shown in the display, and scroll the screen up or down to display other options. The **ENT** key is used to confirm the selected option.

The arrow key ↓ is used to reach the various settings. Once you have found the wanted option, press the confirmation key **ENT** to select it; the current value of the setting is displayed. You can change it by pressing **ENT** again; the value is now flashing and can be modified.

- **Change of Settings (Range)**

To set a number proceed as follows: look for the first digit using the arrow key ↑ (the digit is now flashing). With the arrow key ↓ you go to the second digit, which is now flashing. You can then set this second digit again with the key ↑. Proceed this way until you have completed the setting.

If you do not want to change a flashing digit, press again the down arrow key ↓ to pass to the next digit without changing the anterior. Once you have entered the correct value for the setting, press **ENT** to confirm it and return to that setting's main screen. Move on to a new setting using the key ↓.

The system does not allow a value for a setting outside of the range defined for each setting. If, a value outside the setting range is introduced, the zero value is displayed, the flashing cursor returns to the first digit, and the setting value selection process starts again from the beginning.

- **Change of Settings (Options)**

When the setting consists in selecting an option (pre-established), that option will be looked for indistinctively with the arrow keys ↑. Once the option has been found, press **ENT** to confirm the selection and return to the screen identifying the setting. To move on to a new setting press the down arrow key ↓.

- **Exit Menus or Settings**

Once an operation has been performed, press ↑ to return to the immediate previous level in the menu.



7.3 Screen Sequence Using a Single Key

From the default screen, press the ↓ key to access the following screen sequence:

- Voltage measurement for each side
- Angles difference (between side A and B)
- Frequencies difference (between side A and B)
- Last operation
- LEDs reset display

The general scheme of the screen sequence for last relay operation data is shown in Figure 7.3.

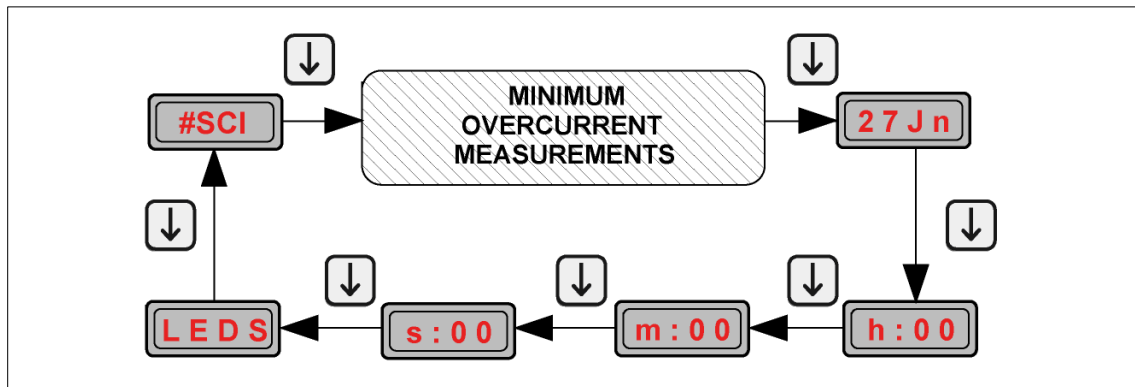

Figure 7.3: Display Screens Sequence for the Last Operation.

The mnemonics significations of this figure are:

- 27 J n** Indicates last operation date (day and month). Months are represented by a two letter code specific of the selected language. If no events are recorded, current date is on display.
- h : 00** Indicates last operation hour. If no operations are recorded, displayed hour would be 00.
- m : 00** Indicates last operation minute. If no operations are recorded, displayed minutes will be 00.
- s : 00** Indicates last operation seconds. If no operations are recorded, displayed seconds will be 00.
- LEDS** From that screen, press the down arrow key ↓ for more than two seconds to reset the LEDs.



Metering elements data screens, and keypad operation are shown in Figure 7.4.

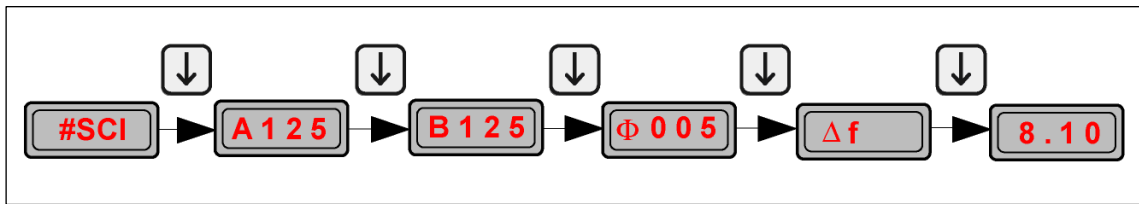

Figure 7.4: Metering Elements Screen Sequence.

The mnemonics significations of this figure are.

A 1 2 5 Side A voltage.

B 1 2 5 Side B voltage.

Φ 0 0 5 Absolute value phase angle difference. Phase angle difference ranges from 0° to 180°. For zero voltage cases at any side (A or B), disabled minimum voltage elements (setting = 000), voltage level at any side below minimum voltage setting, or frequency difference between sides greater than setting this screen will display Φ***.

Δ f Frequency difference (side A and side B). This measurement is divided in two screens. First, the label indicating frequency difference is shown. After pressing the ↓ key, the value is displayed. For zero voltage cases at any side (A or B), disabled minimum voltage elements (setting = 000), or voltage level at any side below minimum voltage setting, this screen will display *.*. Likewise, if the value of the frequency difference measured between the two signals is greater than or equal to 9.99 Hz, the value 9.99 blinking at the display.



7.4 Screen Sequence Using the Complete Keypad

From the default screen, there are a series of screen sequences with loop structure. Press the selection keys (↑ ↓) and the ENT key to access last relay operation data, and the following screen sequences.

- **Settings**
 - general
 - protection
- **Information**
 - contact input status
 - contact output status
- **Configuration**
 - communications
 - language

To see the sequence of screens and the keys used follows an illustrative process table.

- **General Settings: HMI Access**

SETT	GNRL	R_TT	0000
INFO	PROT		
CONF			

- **Protection Settings: HMI Access**

SETT	GNRL	ΛU
INFO	PROT	ΛΦ
CONF		Λf
		UA>
		UB<
		TFIX

- **Information Menu: HMI Access**

SETT	INPT
INFO	OUPT
CONF	

- **Communications Configuration: HMI Access**

SETT		ADDR
INFO	COMM	BAUD
CONF	LANG	STOP
		PARI

- **Language Configuration: HMI Access**

SETT		ENGL
INFO	COMM	ESP
CONF	LANG	POR

8. Receiving Tests



8.1	General	8-2
8.1.1	Accuracy	8-2
8.2	Preliminary Inspection	8-3
8.3	Insulation Test.....	8-3
8.4	Voltage Measuring Test.....	8-4
8.5	Frequency Measuring Test.....	8-4
8.6	Phase Angle Measuring Test.....	8-4
8.7	Synchronism Element Test.....	8-5
8.8	Contact Inputs and LED Targets Test	8-6
8.9	Communications Test	8-7
8.10	Installation	8-7
8.10.1	Location	8-7
8.10.2	Connection	8-7



8.1 General

Improper handling of electrical equipment is extremely dangerous. Damage to equipment and injury to personnel can result when proper safety precautions are not followed. Therefore, only skilled and qualified personnel familiar with appropriate safety procedures and precautions should work with this equipment. The following general safety precautions are provided as a reminder:

- **High magnitude voltages are present in auxiliary supply and measuring circuits even after equipment has been disconnected.**
- **Equipment should be solidly grounded before handling or operating.**
- **Under no circumstances should the operating limits of the equipment be exceeded (auxiliary voltage, current, etc.).**
- **The supply voltage should be disconnected from the unit before extracting or inserting any module; otherwise damage may result.**

The number, the type and the specific characteristics of the acceptance tests for the various models are listed in the following table.

SCI	Preliminary Inspection
	Insulation Test
	Voltage Measuring Test
	Frequency Measuring Test
	Phase Angle Measuring Test
	Synchronism Element Test
	Status Contact Inputs & LED Targets Test
	Communications Test

8.1.1 Accuracy

The results obtained in electrical testing greatly depend on the accuracy of the measuring instruments and test source signals (auxiliary voltage, and measurement voltages). Therefore, verification of the information specified in the Technical Data section of this manual can only reasonably be achieved using test equipment under normal reference conditions and with the tolerances indicated in the **UNE 21-136** and **IEC 255** standards, in addition to using precision instruments.

It is extremely important that there be no distortion (<2%) in the test source signals as harmonics can affect internal measuring of the equipment. For example, distortions will affect this unit, made up of non-linear elements, differently from an AC ammeter, because the measurement is made differently in both cases

It must be emphasized that the accuracy of the test will depend on the instruments used for measuring as well as the source signals used. Therefore, tests performed with secondary equipment should focus on operation verification and not on measuring accuracy.



8.2 Preliminary Inspection

The following aspects of the unit should be examined:

- The unit is in good mechanical condition, all parts are securely attached and no assembly screws are missing.
- The unit model numbers coincide with those specified in the order.

8.3 Insulation Test

While testing for insulation of switchgear and external wiring, it is recommended that the terminal unit be disconnected to avoid damage if the test is not performed properly or if there are shorts in the harness, since insulation testing has been performed on 100 % of the units by the manufacturer:

- **Common Mode**

Wire all the rear connection terminals together except for number 5 and number 30 and any other already wired (connections to external units or internal drivers). Apply 2000 Vac for 1 minute between interconnected terminals and metal case.

- **Transverse Mode**

Divide the terminals into terminal groups as follows:

- * 1-2-3-4
- * 11-12-13-14
- * 15-16-17-18-19-20-21-22-23-24-25-26-27
- * 28-29

Apply 2000 VAC for 1 minute between pairs of terminal groups.

Note: There are internal capacitors that can generate high voltage if the test points for the insulation test are removed without first reducing the test voltage.



8.4 Voltage Measuring Test

Connect the equipment to a suitable power supply (rated Vdc) through terminal connectors 28 (+) and 29 (-). **Ready** LED will illuminate.

Apply a.c. voltage to the Voltage Analog Inputs - terminal connectors 1 and 2 and terminal connectors 3 and 4. Verify that the metering values in the alphanumeric display are within the ranges specified for Measured Value.

Table 8-1: Voltage Measuring Test	
Applied Voltage	Measured Value
X Vac	0.95 X - 1.05 X

8.5 Frequency Measuring Test

Connect the equipment to a suitable power supply (rated Vdc) through terminal connectors 28 (+) and 29 (-). Ready LED will illuminate.

Apply rated voltage at a given frequency to the Voltage Analog Inputs - terminal connectors 1 and 2 and terminal connectors 3 and 4. Verify that the measured values in the alphanumeric display are within the ranges specified for Measured Value.

Table 8-2: Frequency Measuring Test		
Side A Frequency	Side B Frequency	Frequency Difference Measured Value
X	Y	$ X-Y \pm 0,01$

8.6 Phase Angle Measuring Test

Apply rated voltage at rated frequency with a given phase angle to the Voltage Analog Inputs - terminal connectors 1 and 2 and terminal connectors 3 and 4. Verify that the measured phase angle difference in the alphanumeric display is within $\pm 3^\circ$ of the applied phase angle.



8.7 Synchronism Element Test

Connect the equipment to a suitable power supply (rated Vdc) through terminal connectors 28 (+) and 29 (-). Verify that Ready LED (green) illuminates.

Depending on which protection elements are enabled the unit will indicate synchronism condition by closing contacts 15-16 and 17-18, provided that the voltage signals applied are within the ranges adjusted in the protection elements that are enabled (Side A voltage, side B voltage, ΔU , ΔF , and/or Δf).

• Pickup and Reset

To verify pickup and reset values of the different protection elements included in the synchronism unit, make sure that the element under test is the only one enabled. The following tables indicate operational ranges for each element.

Side A or B Voltage		
Setting	Pickup	Reset
XV	$(X \times 1.05) \pm 5\%$	$X \pm 5\%$

ΔU		
Setting	Pickup	Reset
X%	$X\% \pm 5\%$	$(X\% \times 1.05) \pm 5\%$

$\Delta\phi$		
Setting	Pickup	Reset
X°	$X^\circ \pm 3^\circ$	$X^\circ \pm 2.5^\circ$

Δf		
Setting	Pickup	Reset
XHz	$X \pm 0.01$	$(X + 0.005) \pm 0.01$

• Operating Times

Operating times can be verified monitoring the trip outputs (terminals 15-16 or 17-18).

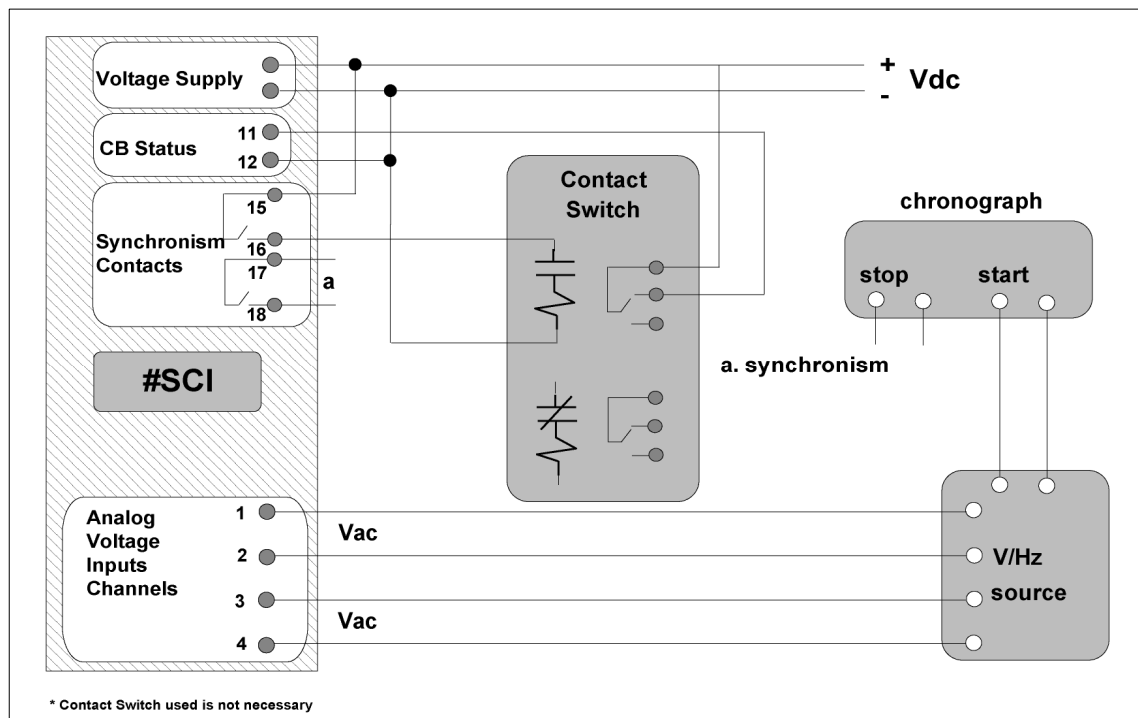

Figure 8.1: Operating Time Test Setup.



Side A or B Voltage		
Setting	Start	Finish
XV	0V	Xx1.2V

ΔU		
Setting	Start	Finish
X%	$V_A=100V$ $V_B=0V$	$V_A=100V$ $V_B=100V$

$\Delta\phi$		
Setting	Start	Finish
α°	$V_A y V_B (V y Hz =)$ $V_A/0^\circ V_B/\alpha^\circ+3^\circ$	$V_A = V_B$ $V_A/0^\circ V_B/\alpha-3^\circ$

Δf		
Setting	Start	Finish
XHz	$V_A y V_B (V \text{ and } \phi =)$ $V_A 50Hz V_B 50.01+x$	$V_A 50Hz$ $V_B 49.97+x$

Voltage element time uncertainty is 5% or 25 ms (whichever is greater). Time uncertainty for the $\Delta\Phi$ and Δf elements is 5% or 100 ms (whichever is greater). Note that for $\Delta\Phi$ and Δf elements time uncertainty, the errors and uncertainties of the supply sources are not take in account.

There are supply sources in which voltage signals cross the zero level. This operation is equivalent to start the test with no voltage. Therefore, operating time increases respect to expected times. It is recommended to perform tests with a starting value near to pickup. In this fashion lost time due to signal changes is minimized.

8.8 Contact Inputs and LED Targets Test

Connect the equipment to a suitable power supply (rated Vdc) through terminal connectors 28 (+) and 29 (-). Ready LED will illuminate.

- **LEDs**

Press the \downarrow key to scroll through the screen sequence until the screen **LEDS** is reached. Then, press the \downarrow key for 2 seconds and verify that all the LEDs illuminate. Release the \downarrow key and verify that all the LEDs turn off.

- **Contact Inputs**

Apply rated voltage to the contact input connectors 11(+) – 12(-) and 13(+) – 14(-). Select from the information menu the inputs status screens and verify that both signals are ON. Disconnect the test probes and verify that both signals are OFF.



8.9 Communications Test

Connect the unit to a suitable power supply (rated Vdc) for the model. The **Ready** LED will illuminate. Use the keypad to set communications to 4,800 bauds in the communications configuration menu. (See Chapter 7, Alphanumeric Display).

Connect to the terminal unit through the local communications port using a male DB9 (9-pin) serial connection wire. Synchronize time using the **ZIVercom**[®] software program. Disconnect the communications wire and disconnect the terminal unit power supply and wait for two minutes. Afterwards, connect the power supply and connect to the terminal unit through the remote communications port. Activate the cyclical mode in the **ZIVercom**[®] software program and verify that the time updates properly.

8.10 Installation

8.10.1 Location

The location where the terminal unit is to be installed should meet the following minimum conditions to ensure correct operation, long service life, and ease of installation and maintenance. These minimum conditions are the following:

- Absence of dust
- Absence of vibration
- Easy access
- Absence of dampness
- Adequate lighting
- Vertical or horizontal mounting

Mounting should be in accordance with the external connections scheme at the end of this instructions manual.

8.10.2 Connection

Terminal 30 must be grounded so that the disturbance-filtering circuits can function. The wire used for grounding these terminals should be stranded 2.5 mm². Ground wire length should be minimized and not exceed 12".



A. Schemes and Drawings



Dimension and Drill Hole Schemes

3SCI	>>4BF0100/0001
3/8SCI	>>4BF0100/0016
Adapter board to 19"x 2U 19"x 2U / 8SCI	>>4BF0100/0026

External Connection Schemes

SCI	>>3RX0132/0004 (generic)
-----	--------------------------

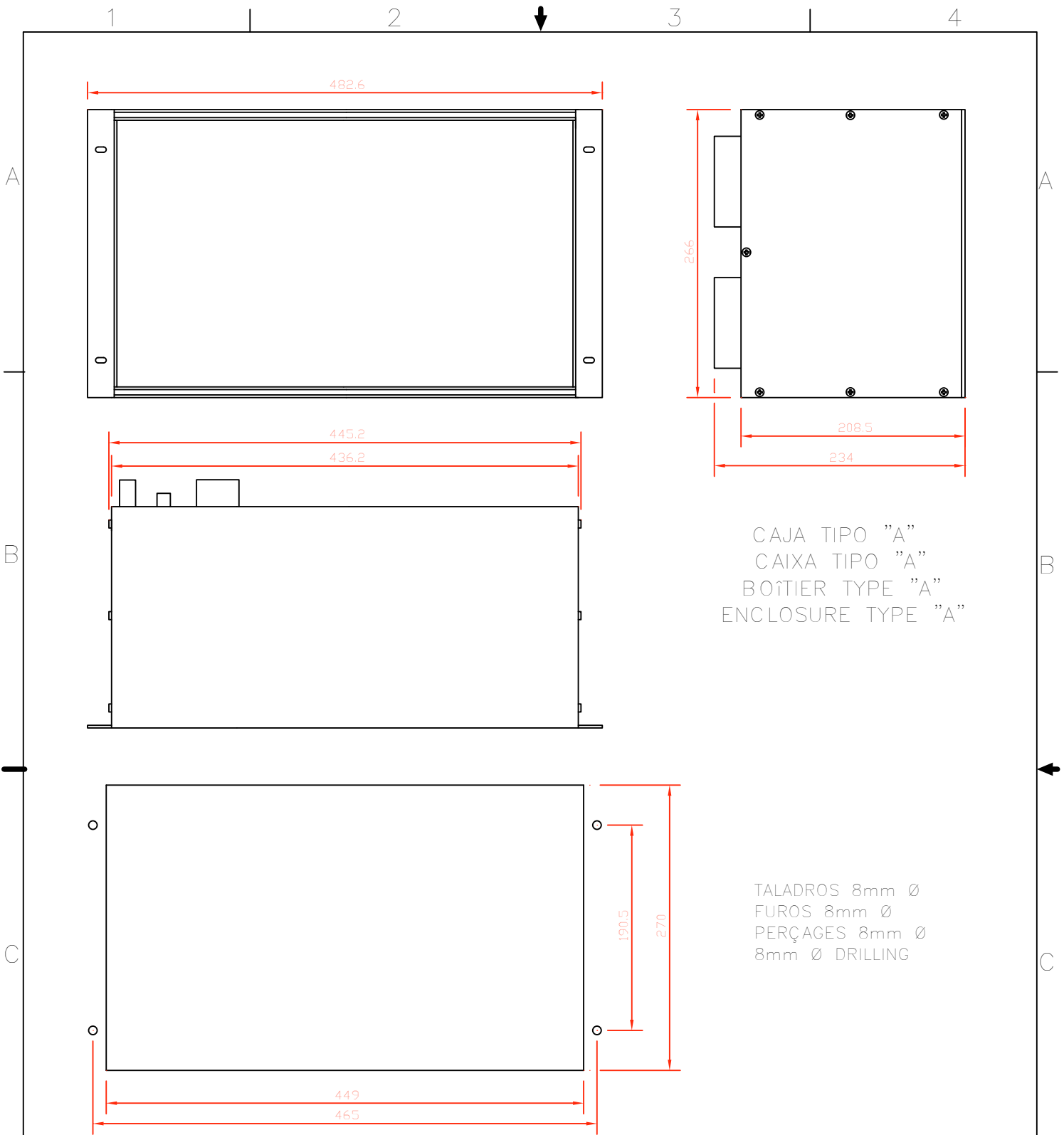

CAJA TIPO "A"
 CAIXA TIPO "A"
 BOÎTIER TYPE "A"
 ENCLOSURE TYPE "A"

TALADROS 8mm Ø
 FUROS 8mm Ø
 PERÇAGES 8mm Ø
 8mm Ø DRILLING

ATENCIÓN: Este documento contiene información confidencial propiedad de ZIV. Cualquier forma de reproducción o divulgación está absolutamente prohibida y puede ser causa de severas medidas legales.

ATENÇÃO: Este documento contém informação confidencial de propriedade de ZIV. Qualquer forma de reprodução ou divulgação está absolutamente proibida e sujeita a severas medidas legais.

ATTENTION: Ce document contient des informations confidentielles propriété de ZIV. Toute forme de reproduction ou de divulgation est formellement interdite et peut faire l'objet de sévères mesures légales.

WARNING: This document contains trade secret information of ZIV. Unauthorized disclosure is strictly prohibited and may result in serious legal consequences.



ZIV Aplicaciones y Tecnología S.L.

TITULO> DIMENSIONES Y TALADRADO

PROYECTO> CAJA TIPO "A" 6U 1RACK

REVISIONES	0	CDN9407106	1	CDR9809104	
2	CD0202125	3	CD0404100	4	CD0901130
5		6		7	
8		9		10	
11		12		13	
14		15		16	

Rev.0
 Rev. 1 10/9/98
 Rev. 2 14/2/02
 Rev. 3 05/4/04
 Rev. 4 05/4/04

NUMERO> 4BF0100/0001

	Fecha	Nombre
Dibujado	20/7/94	R.O.
Aprobado	20/7/94	R.O.

Hoja:1
 Continúa en Hoja:

1

2

3

4

CAJA TIPO "D"
ENCLOSURE TYPE "D"
CAIXA TIPO "D"

A

A

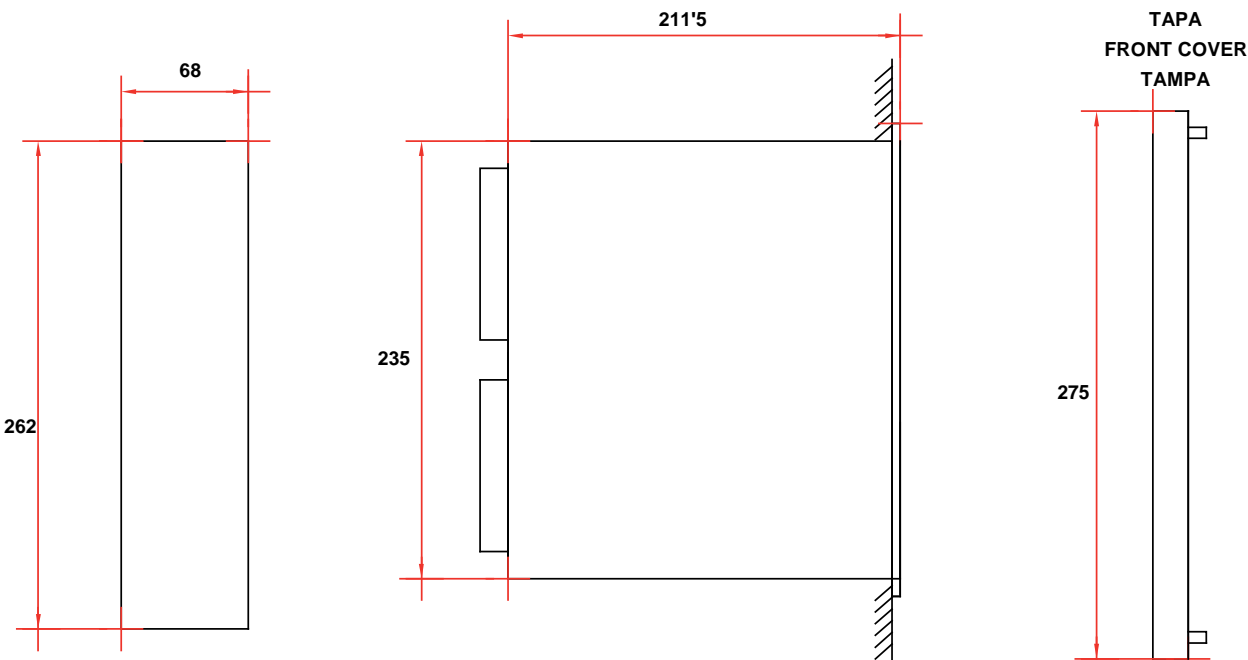

B

B

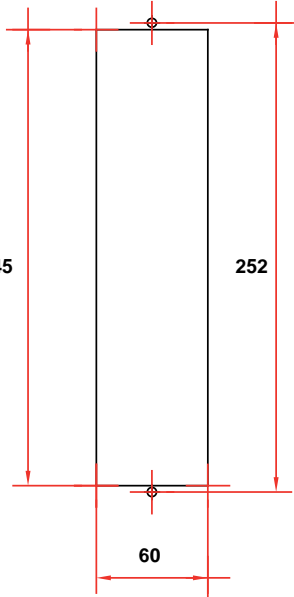
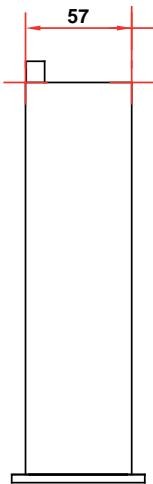

TALADROS 5mm
5mm DRILLING
FUROS 5mm

C

C

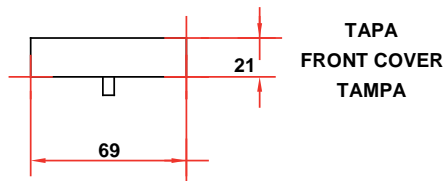

TAPA
FRONT COVER
TAMPA

"ATENCIÓN"
Este documento contiene información confidencial propiedad de ZIV. Cualquier forma de reproducción o divulgación está absolutamente prohibida y puede ser causa de severas medidas legales.

"ATENÇÃO"
Este documento contém informação confidencial de propriedade de ZIV. Qualquer forma de reprodução ou divulgação está absolutamente proibida e sujeita a severas medidas legais.

"WARNING"
This document contains trade secret information of ZIV. Unauthorized disclosure is strictly prohibited and may result in serious legal consequences.

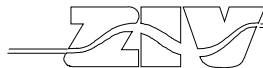

ZIV Aplicaciones y Tecnología, S.L.

TÍTULO: DIMENSIONES Y TALADRADO

PROYECTO: CAJA TIPO "D" 6U 1/7RACK

Rev. 0
Rev. 1 14/9/98
Rev. 2 14/2/02

NÚMERO: 4BF0100/0016

D

D

REVISIONES	0	CDN9605104	1	CDR9809104
2	3		4	
5	6		7	
8	9		10	
11	12		13	
14	15		16	

	Fecha	Nombre	Hoja: 1 Continua en Hoja:
Dibujado	3/5/96	J.C.S.	
Aprobado	3/5/96	R.O.	

1

2

3

4

1

2

3

4

A

A

B

B

C

C

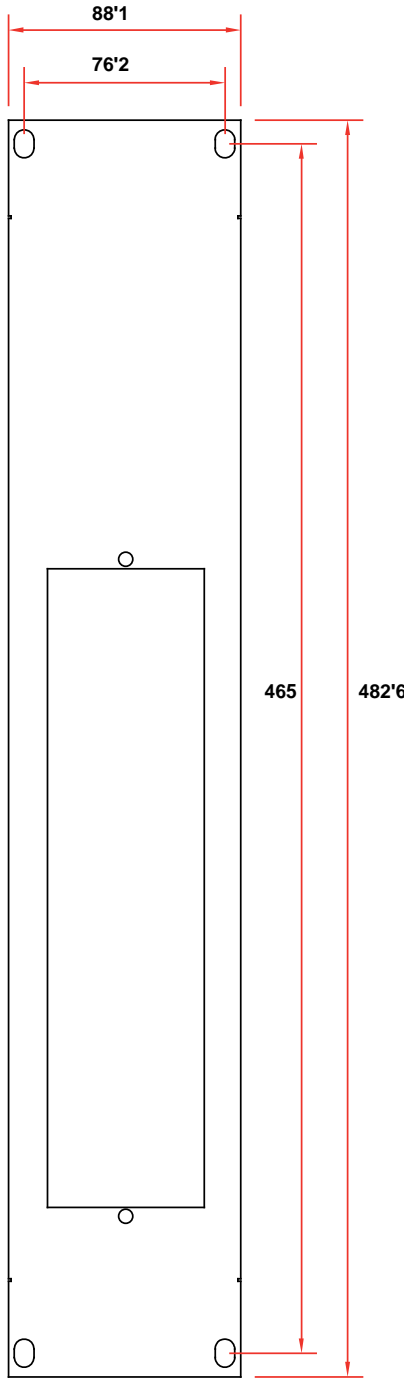

"ATENCIÓN"

Este documento contiene información confidencial propiedad de ZIV. Cualquier forma de reproducción o divulgación está absolutamente prohibida y puede ser causa de severas medidas legales.

"ATENÇÃO"

Este documento contém informação confidencial de propriedade de ZIV. Qualquer forma de reprodução ou divulgação está absolutamente proibida e sujeita a severas medidas legais.

"WARNING"

This document contains trade secret information of ZIV. Unauthorized disclosure is strictly prohibited and may result in serious legal consequences.

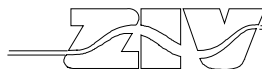

ZIV Aplicaciones y Tecnología, S.L.

TÍTULO: PLACA ADAPTACION A 19`` X 2U

PROYECTO: RELE INDUSTRIAL

Rev. 0
Rev. 14/2/02

NÚMERO: 4BF0100/0026

REVISIONES	0	CDN9904147	1	CD0202125
2	3		4	
5	6		7	
8	9		10	
11	12		13	
14	15		16	

	Fecha	Nombre	Hoja: 1
Dibujado	29/4/99	J.C.S.	Continua en Hoja:
Aprobado	29/4/99	R.O.	

1

2

3

4

D

D

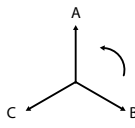

LEDS

- 1.- CLOSE PERMIT (UNLATCHED).
- 2.- TIME DELAYED PICKUP (UNLATCHED).
- 3.- CONFIGURABLE.
- 4.- CONFIGURABLE.
- 5.- CONFIGURABLE.
- 6.- CONFIGURABLE.
- 7.- CONFIGURABLE.

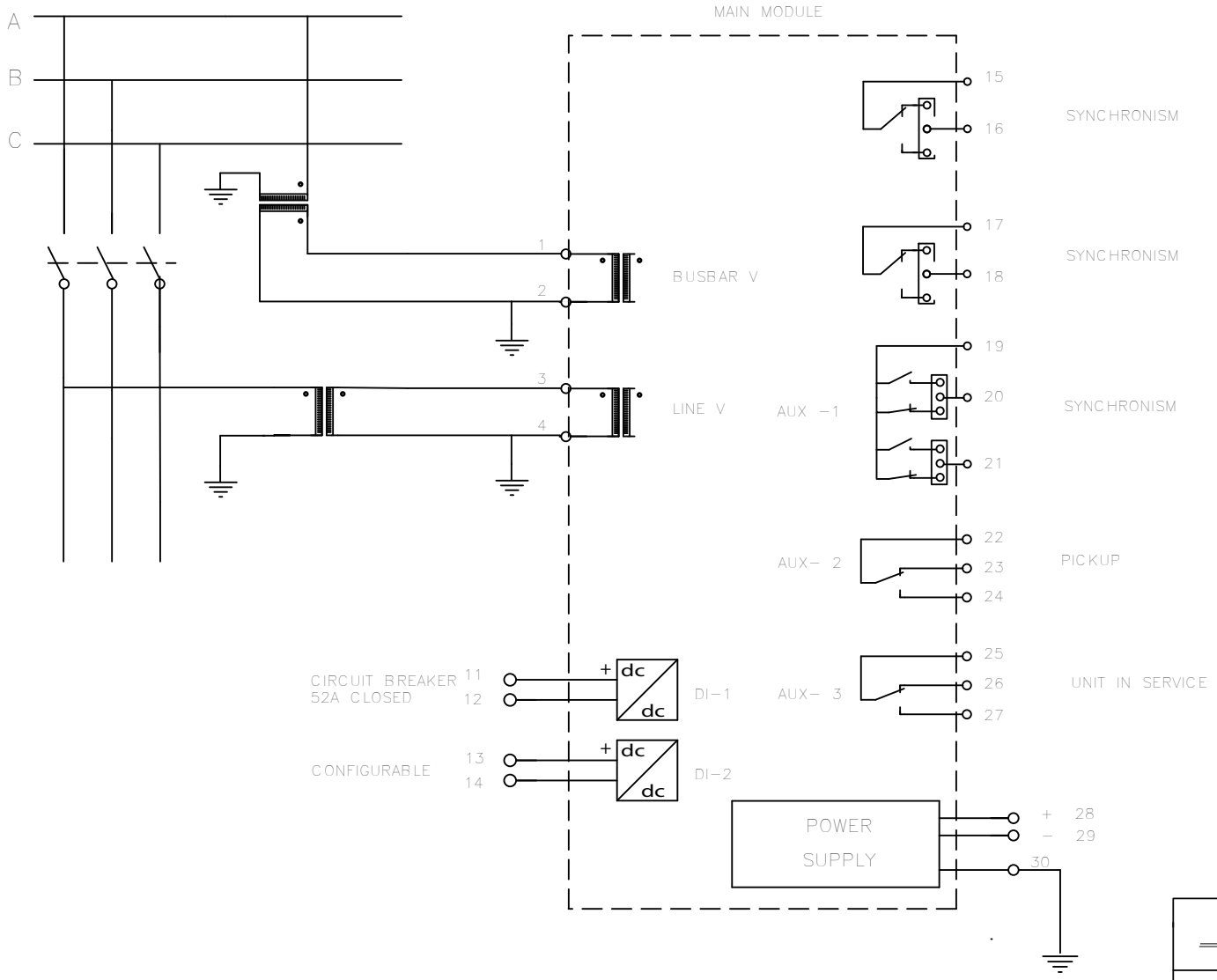

CIRCUIT BREAKER 52A CLOSED 11 12

CONFIGURABLE 13 14

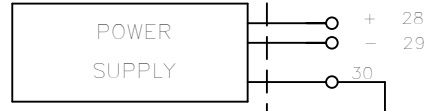

"WARNING"
This document contains trade secret information of Z I V.
Unauthorized disclosure is strictly prohibited and may result
in serious legal consequences.

REVISIONS	0	1	2	3	4
5	6	7	8	9	10
11	12	13	14	15	16

Z I V Aplicaciones y Tecnología, S.L.

TITLE > EXTERNAL CONNECTIONS 3SCI

PROJECT > SYNCHROCHECK UNIT

Rev. **NUMBER >** 3RX0132/0004

	Date	Name	Sheet: 1
Drawn	27/7/99	J.C.S.	Continued on Sheet:
Approved	27/7/99	R.O.	

B. List of Illustrations and Tables



B.1	List of Illustrations	B-2
B.2	List of Tables.....	B-2



B.1 List of Illustrations

4.	Physical Architecture	
4.1	3SCI Front View	4-2
4.2	8SCI Front View	4-2
4.3	8SCI Rear View	4-3
4.4	3SCI Rear View	4-3
5.	Settings	
5.1	Internal Jumpers	5-3
6.	Description of Operation	
6.1	Auxiliary Contact Output Logic Cell Block Diagram.....	6-5
6.2	LED Target Output Logic Cell Block Diagram	6-6
6.3	Schematic for a Synchronism-Check Relay	6-8
6.4	Synchronism Check Example	6-8
6.5	Auxiliary Output Configuration Examples	6-9
6.6	Example of Phase Angle Difference Setting $\Delta\phi$, Δf , and Time Delay	6-10
7.	Alphanumeric Keypad and Display	
7.1	Alphanumeric Display	7-2
7.2	Keypad	7-2
7.3	Display Screens Sequence for the Last Operation.....	7-4
7.4	Metering Elements Screen Sequence	7-5
8.	Receiving Tests	
8.1	Operating Time Test Setup.....	8-5

B.2 List of Tables

6.	Description of Operation	
6-1	Event List	6-3
6-2	Status Contact Inputs.....	6-4
6-3	Auxiliary Contact Output	6-5
6-4	LEDs	6-6
8.	Receiving Tests	
8-1	Voltage Measuring Test.....	8-4
8-2	Frequency Measuring Test	8-4

C. Warranty





ZIV GRID AUTOMATION, S.L. Standard Product Warranty

All new products sold to customers are warranted against defects in design, materials, and workmanship for a period of ten (10) years from the time of delivery (at the moment the product leaves ZIV GRID AUTOMATION premises, as indicated in the shipping documents). Customer is responsible of notifying ZIV GRID AUTOMATION of any faulty conditions as soon as they are detected. If it is determined that the new product defect is covered by the warranty, ZIV GRID AUTOMATION will repair, or substitute the product at its own discretion to the customer at no charge.

ZIV GRID AUTOMATION may, at its own discretion, require the customer to ship the unit back to the factory for diagnosis before making a determination as to whether it is covered by this warranty. Shipping costs to the ZIV GRID AUTOMATION factory (including but not limited to, freight, insurance, customs fees and taxes, and any other expenses) will be the responsibility of the customer. All expenses related to the shipment of the repaired or replacement units back to the customer will be borne by ZIV GRID AUTOMATION.

Customers are responsible for all expenses related to the shipment of defective units back to ZIV GRID AUTOMATION when it is determined that such units are not covered under this warranty or that the fault is not ZIV GRID AUTOMATION's responsibility. Units repaired by ZIV GRID AUTOMATION are warranted against defects in materials, and manufacturing for a period of one (1) year from the time of delivery (at the moment the product leaves ZIV GRID AUTOMATION premises, as indicated by the shipping documents), or for the remaining of the original warranty, whichever is greater.

ZIV GRID AUTOMATION warranty does not cover: 1) improper installation, connection, operation, maintenance, and/or storage, 2) minor defects not interfering with the operation of the product, possible indemnities, misuse or improper usage, 3) abnormal or unusual operating conditions or application outside the specifications for the product, 4) application in any way different from that for which the products were designed, 5) repairs or alterations performed by individuals other than ZIV GRID AUTOMATION employees or an authorised representative.

Limitations:

- 1) Equipment or products provided but not manufactured by ZIV GRID AUTOMATION. Such products may be covered by a warranty issued by the corresponding manufacturer.
- 2) Software: ZIV GRID AUTOMATION warrants that the licensed Software corresponds with the specifications included in the instruction manuals provided with the units, or with the specifications agreed with the end-customer. ZIV GRID AUTOMATION sole and entire liability, and customer exclusive remedy, with respect to any claims relating to the Software shall be to provide a new set of diskettes free of charge.
- 3) In the case that a bank guarantee or similar instrument be required to back up the warranty period, such warranty period, and only for these purposes, will be of a maximum of twelve (12) months from the time of delivery (at the moment the product leaves ZIV GRID AUTOMATION premises, as indicated in the shipping documents).

THIS WARRANTY IS IN LIEU OF ANY OTHER WARRANTIES AND ZIV GRID AUTOMATION HEREBY DISCLAIMS ANY OTHER WARRANTY, EXPRESS OR IMPLIED, INCLUDING, WITHOUT LIMITATION, ANY WARRANTY OF MERCHANTABILITY OR FITNESS FOR A PARTICULAR PURPOSE. IN NO EVENT SHALL ZIV GRID AUTOMATION BE LIABLE FOR ANY INDIRECT, INCIDENTAL, CONSEQUENTIAL, OR SPECIAL DAMAGES OR FOR ANY OTHER LOSS, INJURY, DAMAGE, OR EXPENSE OF ANY KIND INCLUDING LOST PROFITS OR ANY OTHER PECUNIARY LOSS ARISING FROM ANY SOURCE.

ZIV GRID AUTOMATION, S.L.
Parque Tecnológico, 210
48170 Zamudio - Bizkaia - Spain
Tel.- (+34)-(94) 452.20.03
Fax - (+34)-(94) 452.21.40